

# UT281E+

## 10000A FLEX CLAMP

### User Manual



## Preface

Thank you for purchasing a new Uni-Trend meter, in order to use this meter correctly, please read the full text of the manual carefully before use, especially the "Safety information" part.

If you have read the full text of this manual, it is recommended that you keep it in a safe place, with the instrument or in a place where you can access it at any time, so that you can access it in future use.

## Limited warranties and liabilities

Uni-Trend warrants that this product will be free from defects in materials and workmanship for a period of one year from the date of purchase. This warranty does not apply to fuses, disposable batteries, or damage caused by accident, negligence, misuse, modification, contamination, and abnormal operation or handling. The distributor is not entitled to any other warranties in the name of Uni-Trend. If you need warranty service during the warranty period, please contact your nearest Uni-Trend authorized service center to obtain the product return authorization information, then send the product to the service center with a description of the problem.

This guarantee is your sole remedy. Otherwise, Uni-Trend does not provide any express or implied warranties, such as implied warranties for a particular purpose. Uni-Trend shall not be liable for any special, indirect, incidental or consequential damages or losses arising from any cause or speculation. Because some states or countries do not allow limitations on implied warranties and incidental or consequential damages, the above limitations and provisions of liability may not apply to you.

## Contents

- 一、 Overview
- 二、 Features
- 三、 Unpack to check
- 四、 Safety information
- 五、 Electrical symbols
- 六、 General characteristics
- 七、 External structure
- 八、 LCD display
- 九、 Slide switch and functional buttons
- 十、 Operating instructions
- 十一、 Specifications
- 十二、 Maintenance and repair

## 一、 Overview

UT281E+ is a stable, safe and reliable 10000A AC true RMS digital Rogowski coil clamp meter (hereinafter referred to as flexible clamp meter). The circuit design of the meter is based on the large-scale integration of integral A/D converter as the core. The full-scale overload protection circuit and the unique appearance design make UT281E+ a new generation of electrical measuring instrument with superior performance and more practicality. The length of the Rogowski coil 1100 mm (43 inches). The meter can be used to measure: AC and DC voltage, resistance, continuity, frequency, AC current, inrush, etc. It has functions such as data hold, data storage, undervoltage warning, backlight and automatic shutdown.

It can be used as a special measurement tool for the detection, maintenance and repair of various distribution stations, smelting, communications, manufacturing, petroleum, national defense, electric power, electrician, photovoltaic machine stations, and circuit power equipment, so as to better solve the measurement requirements of factory automation, power distribution and electromechanics.

## 二、 Features

- 1) Lightweight, easy to operate with one hand and at heights.
- 2) All-round anti-misoperation protection, up to 1000V (30KVA) energy impact, and set over-voltage and over-current alarm prompts
- 3) 10A, 100A, 1000A, and 10KA automatic ranges. The frequency response is up to 45Hz~500Hz, and the inrush measurement function is also available.
- 4) Over-voltage and over-current alarm
- 5) Large area of red backlight
- 6) It has the functions of data hold, storage, recall and deletion
- 7) Dual display function: AC voltage-frequency (secondary display), flexible coil AC current-frequency (secondary display)
- 8) The circuit is set with automatic power-saving function, which consumes <math><30\mu\text{A}</math> in the automatic shutdown state, effectively extending the service life of the battery up to 200 hours.

Please carefully read the contents of this manual regarding "safety" and "warning notices", and strictly follow all warning precautions.

 Warning:

Please read the "Safety information" carefully before use.

### 三、 Unpack to check

This instruction manual includes relevant safety information and warning tips, etc., please read the relevant content carefully and strictly follow all warnings and precautions. Open the box and take out the meter, carefully inspect the following accessories for missing or damaged, and contact your supplier immediately if you notice any missing or damaged.

1. User manual :1 pc
2. Test leads:1 pair
3. 1.5V AAA battery :3 pcs

### 四、 Safety information













Please pay attention to the "Warning Signs and Warning Words". A warning indicates a situation or action that poses a danger to the user and may cause damage to the meter or device under test.

This meter is designed according to IEC/EN61010-1, 61010-2-032 electromagnetic compatibility EN61326-1 safety standards, in line with double insulation, overvoltage standards CAT III 1000V, CAT IV 600V and pollution level 2, indoor use. Failure to use the meter in accordance with the instructions may weaken or lose the protection afforded to you.

1. Check the meter and test lead before use, beware of any damage or abnormal phenomenon, do not use if you find any abnormal situation: the test lead is exposed, the case is damaged, abnormal display occurs, etc.
2. It is strictly forbidden to use the meter without a proper cover, otherwise there is a risk of electric shock.
3. If the test lead is damaged, it must be replaced with a test lead of the same model or the same electrical specification.
4. Do not touch exposed wires, connectors, unused inputs, or circuits being measured.
5. When measuring voltages higher than 30V DC or 30V AC, be cautious and remember not to exceed the finger guard of the test lead to prevent electric shock.

6. If the range of the measured value cannot be determined, the instrument must be operated at the maximum range position.
7. Never apply more voltage or current than indicated on the meter between terminals, or between any terminal and ground.
8. The functional switch must be placed in the correct position during measurement. Before the functional switch is converted, the test leads must be disconnected from the circuit under test, and it is strictly forbidden to change position during measurement to prevent damage to the instrument.
9. Before performing in-line resistance, diode, or continuity measurement, all power supplies in the circuit where the device under test is located must be cut off and all capacitors must be discharged completely.
10. Do not use the low-pass filter option to verify the presence of dangerous voltages, there may be voltages that exceed the indicated values. First, the voltage is measured without a filter selected to detect the presence of a dangerous voltage, then select the filter function.
11. Only use a test lead with the same rated voltage, frequency, type and current rating as the meter and a test lead that has been approved by a safety certification body.
12. Before opening the battery cover, remove the test lead from the meter.
13. When using the probe, the fingers should be held behind the finger guard of the probe.
14. Do not store or use the meter in high temperature, high humidity, flammable, explosive and strong electromagnetic field environment
15. Do not change the internal wiring of the instrument at will, so as not to damage the instrument and endanger safety.
16. When the LCD display shows the "" symbol, the battery should be replaced in time to ensure the measurement accuracy.
17. The power should be turned off in time after the measurement is completed. When not in use for a long time, the battery should be removed.
18. Please measure the known voltage or current in the product before use to ensure that the product is working properly.
19. Use test leads that meet IEC/EN/UL 61010-031 standard, with identical electrical specifications or better.
20. Do not use beyond the rated frequency.

## 五、 Electrical symbols

	Do not dispose of the device and its accessories in the trash, dispose of them properly in accordance with local regulations.		Battery
	AC (Alternating current)		DC (Direct current)
	AC (Alternating current)/DC (Direct current)		Warning prompts
	High voltage warning		Grounding
	Double insulated		Insufficient battery power
CAT III	MEASUREMENT CATEGORY III is applicable to test and measuring circuits connected to the distribution part of the building's low-voltage MAINS installation		
CAT IV	MEASUREMENT CATEGORY IV is applicable to test and measuring circuits connected at the source of the building's low-voltage MAINS installation		
	Complies with the European Union directive		
	Complies with UL STD 61010-1, 61010-2-032, certified to CSA STD C22.2 NO.61010-1, 61010-2-032.		
	Do not apply current sensor to or remove from HAZARDOUS LIVE UNINSULATED CONDUCTORS, which may render electric shock, electric burn, or arc flash		

## 六、 General characteristics

1. Maximum voltage between signal input terminal and COM terminal: See the description of the input protection voltage of each range for details.
2. Display count: 6000
3. The display is updated about 2~3 times per second.
4. Range: Automatic.
5. Polarity display: Automatic.
6. Overrange Prompt: "OL" or displayed.
7. Test Position Error: When measuring current, the additional error of the reading will occur because the source to be measured is not placed in the center position of the clamp.
8. Impact resistance: Able to withstand the impact of landing at a height of 1m.
9. Low battery indication:  $\leq$  about 3.6V.
10. Power supply: 3 AAA 1.5V batteries
11. Auto-off function: The meter will automatically power off when no button is pressed for about 15 minutes, and the function can also be turned off as needed.
12. Operating temperature:  $0^{\circ}\text{C} \sim 40^{\circ}\text{C}$  ( $32^{\circ}\text{F} \sim 104^{\circ}\text{F}$ )
13. Storage temperature:  $-10^{\circ}\text{C} \sim 50^{\circ}\text{C}$  ( $14^{\circ}\text{F} \sim 122^{\circ}\text{F}$ )
14. Relative humidity:  $\leq 75\%$  (below  $0^{\circ}\text{C} \sim 30^{\circ}\text{C}$ );  $\leq 50\%$  ( $30^{\circ}\text{C} \sim 40^{\circ}\text{C}$ )
15. Operating altitude:  $\leq 2000\text{m}$
16. Electromagnetic compatibility: As per EN61326-1: and EN61326-2-2:standards.
17. Weight: 258.4g
18. Safety standard: IEC/EN/UL 61010-1: CAT III 1000V / CAT IV 600V
19. Pollution degree: 2



## 七、 External structure (Figure 1)

1. Clamp lock
2. LCD display
3. Functional buttons
4. Slide switch
5. Input terminal
6. Screw for fixing battery compartment

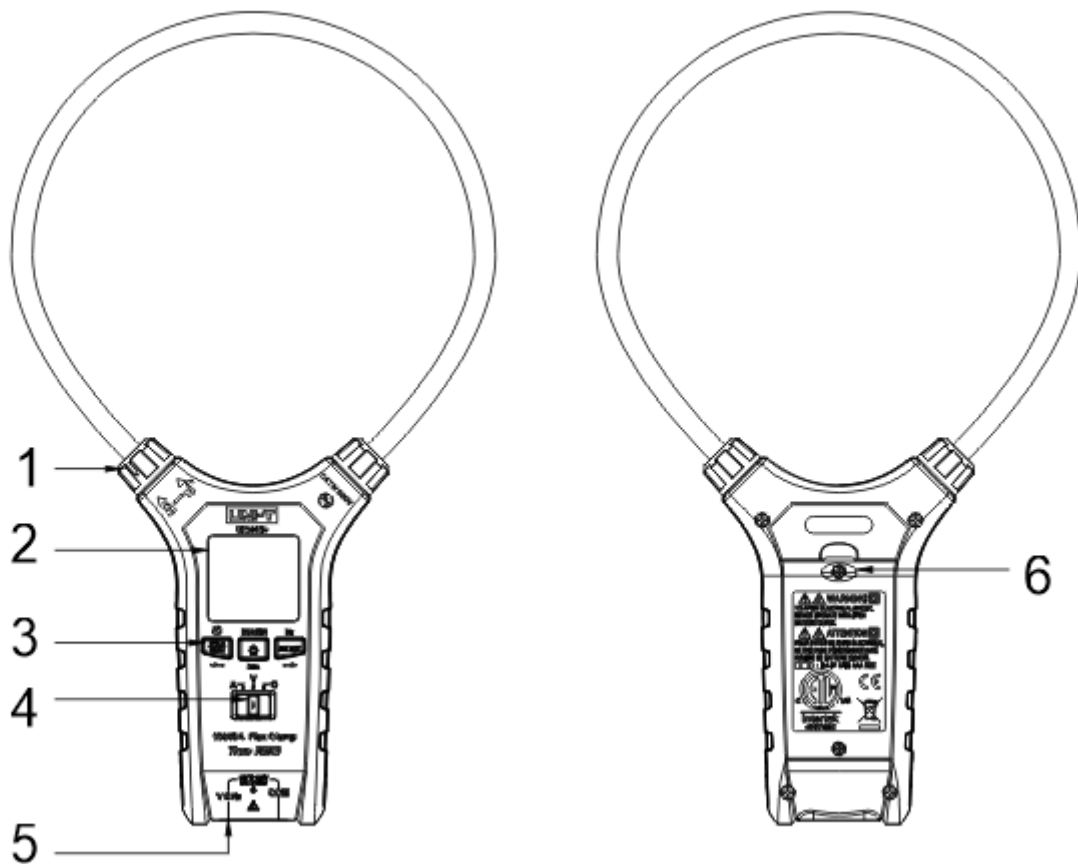

Figure 1

## 八、 LCD display (Figure 2)

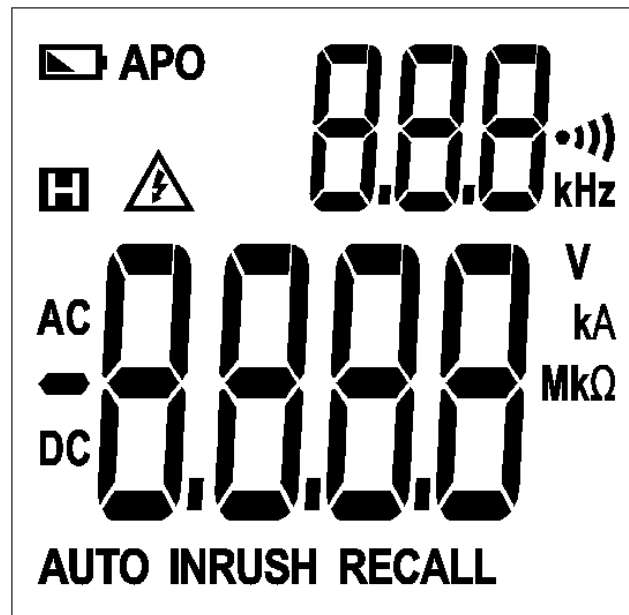





Figure 2

Symbol	Description
	Symbol for warning AC/DC voltage higher than 30V
	Data Hold Prompt
<b>RECALL</b>	Data recall prompt
<b>-</b>	Negative readings
<b>AC</b>	AC measurement prompt
<b>DC</b>	DC measurement prompt
	Low battery prompt
<b>AUTO</b>	Autoranging prompt
<b>APO</b>	Automatic shutdown prompt
<b>MkΩ</b>	Resistance units: ohm, kiloohm, megaohm
<b>V</b>	Voltage unit: volt
<b>kA</b>	Current units: kiloamp, amp
<b>INRUSH</b>	Inrush measurement prompt
<b>kHz</b>	Frequency units: kilohertz, hertz
	Circuit on-off measurement prompt

## 九、 Slide switch and functional buttons

Position	Description
	AC and DC voltage measurements
	AC current measurement
	Continuity/Resistance measurement

Descriptions of buttons:

Short press: Hold down the button for <2s

Long press: Hold down the button for ≥2s

1. :

- 1) Short press to hold and save data
- 2) Long press to power on/off

2. :

- 1) Voltage position: Short press to select ACV->DCV.
- 2) Frequency position: In AC voltage long press and AC current measurement mode, Short press to enter the frequency measurement.
- 3) Inrush measurement: Short press to switch the range.

3. :

- 1) Short press to start and turn off the backlight function.
- 2) Long press to enter the INRUSH function, short press again to refresh the current measured value, and long press to exit the current mode.

4.  + :

- 1) Long press the SELECT and HOLD buttons at the same time to view the stored data. Arrow direction (viewing the stored step data)
- 2) Long press the  button (ESC) to clear all data and automatically return to the measurement interface. To exit the current viewing interface, long press the SELECT and HOLD buttons at the same time.
- 3) Continuously short the ESC button twice to clear a single data.

5.  + :

- 1) Long press the backlight and HOLD buttons at the same time to disable the auto-off function.

## 十、 Operating instructions

First of all, please pay attention to check the built-in AAA 1.5V×3 battery, if the "🔋" symbol appears on the display after powering on, you must replace the battery in time before use. Also pay attention to the symbol "⚠️" next to the socket of the test lead, which warns that the voltage being tested should not exceed the indicated number to ensure the safety of the measurement!

### 1. AC/DC voltage and frequency measurement (Figure 3)

- 1) Set the functional switch to the AC/DC voltage position.
- 2) This position defaults to the AC voltage position. To measure DC voltage, please short press the SELECT button to enter the DC voltage position.
- 3) Long press the SELECT button in AC voltage position to start the frequency measurement function.
- 4) Connect the red test lead to the red terminal (V) and the black test lead to the black terminal (COM), then touch the test lead to both ends of the measured voltage respectively (connected to the load in parallel).
- 5) The flexible clamp meter will automatically select an appropriate range, the main display will show the true RMS value of the AC voltage, and the secondary display will show the frequency.

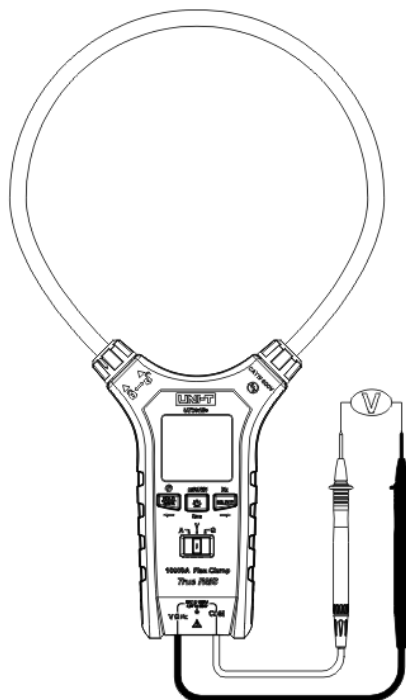

Figure 3

⚠ Warning:

- \*.When measuring high voltage, pay special attention to safety and avoid electric shock!
- \*.Before use, you can test the known voltage to confirm whether the product function is intact!

## 2. AC current and frequency measurement

- 1) Set the functional switch to the AC voltage position.
- 2) Rotate the lock of the flexible coil to unlock, completely clamp the coil around the conductor to be measured, and then rotate the lock to lock the coil. (Note that the clamp must be fully closed, see Figures 4.1 and 4.2)
- 3) The meter can only measure one current conductor at a time, if two or more current conductors are measured at the same time, the measurement reading is wrong. (See Figure 4.3)
- 4) The flexible clamp meter will automatically select an appropriate range, the main display will show the true RMS value of the AC current, and the secondary display will show the frequency.
- 5) Short press the "SELECT" button in the AC current position to enter the current frequency measurement.
- 6) Long press the "INRUSH" button in the AC current position to select the inrush current measurement, start the electrical appliance, and measure the instantaneous starting current of the electrical appliance. For inrush current measurement, there are 100A and 6000A ranges, which can be switched by pressing the SELECT button.
- 7) Do not perform the following improper operations. (see Figure 4.4)

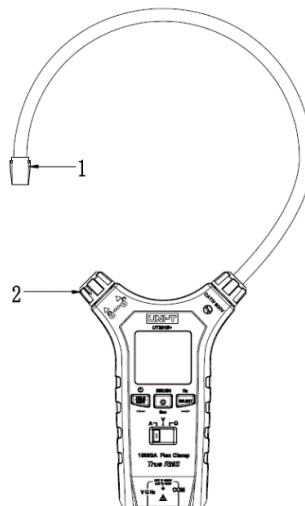

Figure 4.1

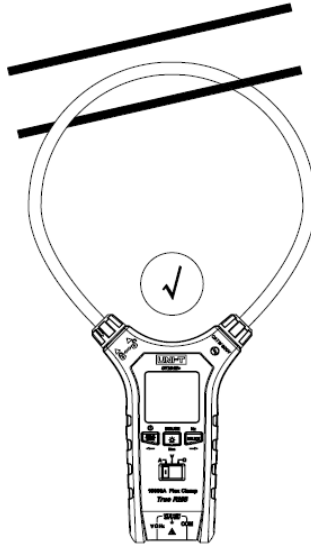

Figure 4.2

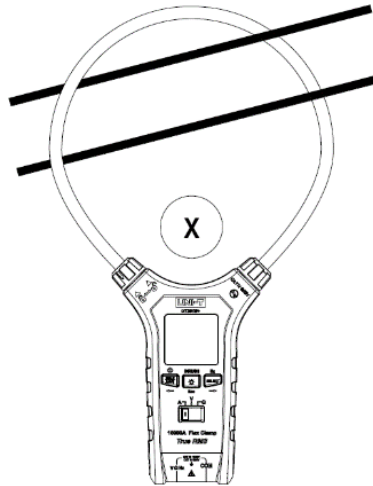

Figure 4.3

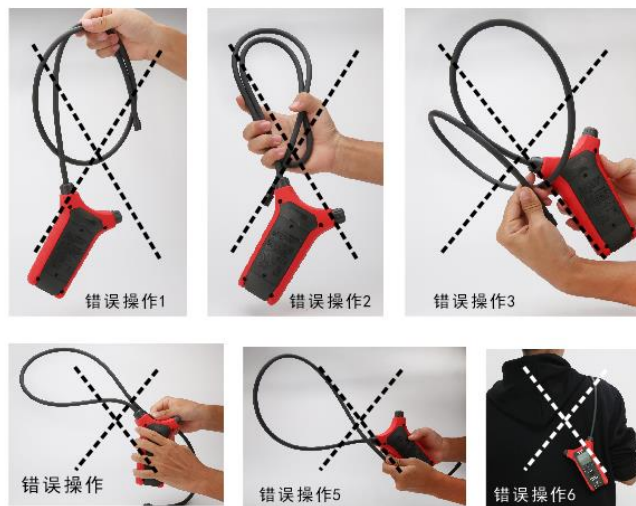

Figure 4.4

⚠ Warning:

- \*. The current measurement function must be operated between 0°C~40°C, hold down the lever and do not release it suddenly, the instrument measurement has different degrees of sensitivity to mechanical stress, and the impact will cause a short-term reading change.
- \*. To ensure the accuracy of the measurement data, the conductor to be measured must be placed in the center of the clamp head, and failure to place it in the center of clamp head will result in an additional error of the reading.
- \*. When the meter shows "OL", please refrain from continuing the test. There is a risk of damaging the meter after a long time of testing, so it should be replaced with a larger-range meter for measurement.

De-energise the installation on which the current is measured, or to adopt safe operating procedures when working on HAZARDOUS LIVE installations, during application and removal of Type B current sensors;

Individual protective equipment should be used if HAZARDOUS LIVE parts in the installation where measurement is to be carried out could be ACCESSIBLE;

### 3. Continuity and resistance measurement (Figure 5)

- 1) Set the functional switch to the resistance measurement position.
- 2) This position defaults to the automatic identification mode, which can automatically identify the continuity and resistance measurement.
- 3) Connect the red test lead to the red ( $\Omega$ ) terminal and the black test lead to the black (COM) terminal, and touch the two test probe tips to both ends of the measured object (connected to the measured object in parallel).

For continuity measurement, if the resistance between the two ends to be measured  $\geq 50\Omega$ , it is considered that the circuit is open and the buzzer is silent; if the resistance between the two ends to be measured is  $\leq 30\Omega$ , the circuit conductivity is considered to be good, and the buzzer beeps continuously.

- 4) Read the measured resistance value directly from the display.

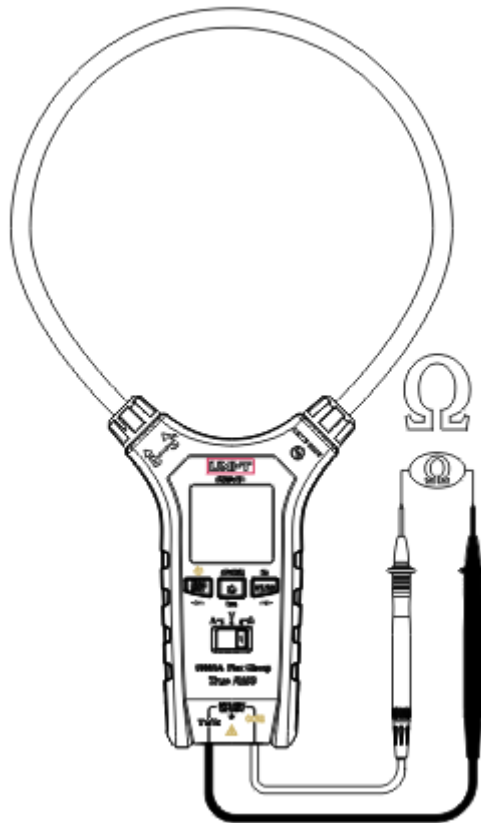











Figure 5

⚠ Warning:

- \*.When measuring continuity or resistance online, in order to avoid damage to the meter and injury to the user, all power supplies in the circuit under test must be turned off before measurement, and all capacitors must be discharged completely before measurement.
- \*.If the resistance value is not less than  $0.5\Omega$  when the test lead is shorted, please check the test lead for looseness or other abnormalities.
- \*.If the resistance to be measured is open or exceeds the range of the meter, the display will show "OL".
- \*.In the low resistance measurement, the test lead will cause the lead to have a resistance measurement error of  $0.1\Omega\sim 0.2\Omega$ , in order to obtain an accurate value, you can use the measured resistance value to subtract the resistance value of the shorted red and black test leads, and then the final resistance value can be obtained.
- \*. When measuring high impedance, it is normal to take several seconds to stabilize the reading.
- \*. Do not input voltages higher than DC or AC 30V to avoid personal injury.



#### 4. Data hold/save/recall/deletion

- 1) Data hold and save: Short press the " " button, the LCD will show the " " prompt to keep the current measurement data, and automatically number and save it, and short press the " " button again to cancel the data hold.
- 2) Data recall: Long press the " " and " " buttons at the same time, the LCD will show the "RECALL" prompt and the Meter will enter the data recall interface. View the stored data according to the direction of the arrow on the panel.
- 3) Data deletion: Long press the " " button () in the data recall interface, the LCD flashes "NULL" three times, the buzzer sounds a prompt, and the Meter automatically returns to the measurement interface, which indicates all stored data has been deleted.  
  
To delete a single data, please select the data to be deleted and short press the " " button () twice continuously, the LCD will show "NULL" for 1S, then the main display shows "- - -" and the secondary display shows the number of the deleted data, indicating the single data has been deleted successfully.



#### Warning:

- \*.999 sets of data can be stored. LCD flashes "FULL" to indicate full storage, and the data needs to be cleared before storing new data.
- \*.When entering the data query interface, the LCD flashes "NULL", and then the meter automatically returns to the measurement interface, to indicate that the data storage is blank.
- \*.For AC voltage and current data storage and viewing, the secondary display will show the number for about 1 second, and then switch to the current AC voltage and current frequency value. When DC voltage, resistance, frequency, and inrush current are measured, the secondary display turns off after it shows the number for about 1 second.

#### 5. Other functions

- 1) If there is no operation for 15 minutes during the measurement process, the meter will automatically power off and enter the energy-saving state. To turn on the meter in the auto-shutdown state, please long press the " " button again. To disable the auto-off function, please long press the HOLD and backlight buttons (the symbol "APO"

disappears with the buzzer beeping three times). To enable the auto-off function, please restart the Meter.

- 2) High voltage alarm display: In ACV/DCV mode, when the amplitude of the voltage measurement value is  $\geq 30V$  or the OL is displayed due to the overrange, the LCD shows the high voltage warning symbol “”.
- 3) High voltage over-range alarm: In ACV/DCV mode (and the amplitude of the voltage measurement value is  $\geq 600 V$ ), when the white backlight is off, the red backlight flashes; When the white backlight is on, the red/white backlight flashes back and forth
- 4) OL is displayed when ACV/DCV is  $>1010V$  and ACA is  $>10.10kA$ .
- 5) Low voltage detection: When the battery voltage is lower than the about 3.6V, the battery undervoltage symbol “” is displayed
- 6) Under-voltage shutdown function: When the battery voltage is about 3.3V, the battery under-voltage symbol “” will be displayed and the "LBT" interface will appear on the LCD for seconds, then the Meter powers off automatically after the buzzer beeps for three times.
- 7) Dual display function: AC voltage-frequency (secondary display), flexible coil AC current-frequency (secondary display).
- 8) Buzzer: When pressing any enabled button or toggling the functional switch, the buzzer will make a "Beep" sound (about 0.25 seconds). When measuring voltage or current, the buzzer will make intermittent "Beep" sounds to indicate an overrange warning.

## 十一、 Specifications

Accuracy:  $\pm (A\% \text{ reading} + B \text{ count})$ , with a 1-year warranty

Ambient temperature:  $0^{\circ}C \sim 40^{\circ}C$  ( $32^{\circ}F \sim 104^{\circ}F$ ). Relative humidity:  $\leq 75\%$

 Warning :

- Accuracy is guaranteed at temperatures ranging from  $18^{\circ}C$  to  $28^{\circ}C$ , and the fluctuation range of ambient temperature is stable within  $\pm 1^{\circ}C$ . At a temperature  $< 18^{\circ}C$  or  $> 28^{\circ}C$ , the additional temperature coefficient error is  $0.2 \times (\text{specified accuracy})/^{\circ}C$ .

### 1. DC voltage measurement

Range	Resolution	Accuracy
-------	------------	----------

6.000V	0.001V	± (0.8%+2)
60.00V	0.01V	
600.0V	0.1V	
1000V	1V	± (1.0%+2)

- \*.The voltage input impedance is about 10MΩ, and “OL” will be displayed if the maximum value is ≥1010V.
- \*.Overload protection: 1000Vrms (DC/AC)
- \*.Accuracy guarantee range: 1~100% range
- \*.The offset under open circuit condition is ≤3 counts, and the reading under short-circuit input condition is zero.

## 2. AC voltage measurement

Range	Resolution	Accuracy
6.000V	0.001V	± (1.0%+3)
60.00V	0.01V	
600.0V	0.1V	
1000V	1V	± (1.2.%+3)

- \*.The voltage input impedance is about 10MΩ, and "OL" is displayed when the maximum value is ≥1010V.
- \*.Frequency response: 45Hz~500Hz, sine wave RMS (true RMS response)
- \*.Overload Protection: 1000Vrms (DC/AC)
- \*.Accuracy guarantee range: 5~100% range.
- \*.The offset under open circuit condition is ≤10 counts (with test lead disconnected) , and the reading under short-circuit input condition is ≤2 counts.

## 3. AC current measurement

Range	Resolution	Accuracy	Remark
9.99A	0.01A	± (2.0%+5)	The specifications in this table are for the center position.
99.9A	0.1A		

999A	1A	$\pm (2.5\%+5)$	Note: The specifications for Area A, B and C are shown in the table below.
9.99kA	0.01kA	$\pm (3.0\%+5)$	
Inrush current measurement	Measuring range: 5.00A~6000A	$\pm 10\%$	

The accuracy for optimal measurement at the center position (no other electric or magnetic fields externally)	50mm (1.97 inches)	The accuracy is added by 2.0% at current range.	Area A	
	100 mm (3.94 inches)	The accuracy is added by 2.5% at current range.	Area B	
	150mm (5.91 inches)	The accuracy is added by 3.0% at current range.	Area C	

- \*.Frequency response: 45Hz~500Hz
- \*.Overload protection: Not specified
- \*.Accuracy guarantee range: 10%~100% range
- \*.The offset is  $\leq 5$  counts when there is no input to the clamp head.
- \*.For inrush current measurement, the trigger value is 5A at 100A position (20A at 6000A position) and the trigger time is about within 100ms.

#### 4. Resistance measurement

Range	Resolution	Accuracy
600.0 $\Omega$	0.1 $\Omega$	$\pm (1.0\%+5)$
6.000k $\Omega$	0.001k $\Omega$	
60.00k $\Omega$	0.01k $\Omega$	
600.0k $\Omega$	0.1k $\Omega$	
6.000M $\Omega$	0.001M $\Omega$	$\pm (2.0\%+5)$
60.00M $\Omega$	0.01M $\Omega$	$\pm (2.5\%+5)$

\*. Range: Measured value = Measured displayed value - Short circuit value of the test lead

- \*. Overload protection: 600Vrms (DC/AC)
- \*. Accuracy guarantee range: 1~100% range.

### 5. Continuity

Range	Resolution	Remark
	0.1Ω	ON: About 30Ω, the buzzer sounds. OFF: ≥50Ω, the buzzer keeps silent. Buzzer sound: ≥70dB (Whichever is best)

- \*. Range: Measured value = Measured displayed value - Short circuit value of the test lead
- \*. Overload protection: 600Vrms (DC/AC)
- \*. Accuracy guarantee range: 1~100% range.

### 6. Frequency measurement

Range	Resolution	Testing sensitivity	Accuracy
Voltage frequency measurement range: 10.0Hz~30.0kHz	0.1Hz~0.1kHz	10.0Hz~30.0kHz	± (0.5%+3)
Voltage frequency measurement range: 10.0Hz~1000Hz	0.1Hz~0.1kHz	10.0Hz~1000Hz	± (0.5%+3)

- \*. Overload protection: 600Vrms (DC/AC)
- \*. Frequency position: Voltage frequency ≤30kHz, 2Vrms≤input amplitude≤240Vrms;  
Current frequency≤1000Hz, input amplitude≥1A.

## 十二、Maintenance and repair (Figure 6)

⚠ Warning: Before opening the back cover or the battery cover, make sure that the power is off and the test lead has been removed from the input terminal and the circuit under test.

### 1. General maintenance and repair

- Use a damp cloth and mild detergent to clean the meter housing, do not use abrasives or solvents.
- If there is any abnormality in the instrument, stop use immediately and sent for maintenance.
- The meter shall be repaired by a qualified professional maintenance personnel or designated service center.

### 2. Battery installation or replacement

The built-in battery specifications of this product are: AAA battery

When the LCD shows a low battery prompt, the built-in battery should be replaced immediately, otherwise the measurement accuracy will be affected.

Install or replace the batteries in the following order:

- a. Turn off the meter and remove the test lead from the input terminal.
- b. Turn the instrument panel down, unscrew the battery compartment screws, unplug the battery cover, take out the battery, and install the new battery according to the polarity instruction.
- c. After installing the new battery, install the battery cover and lock the screws.

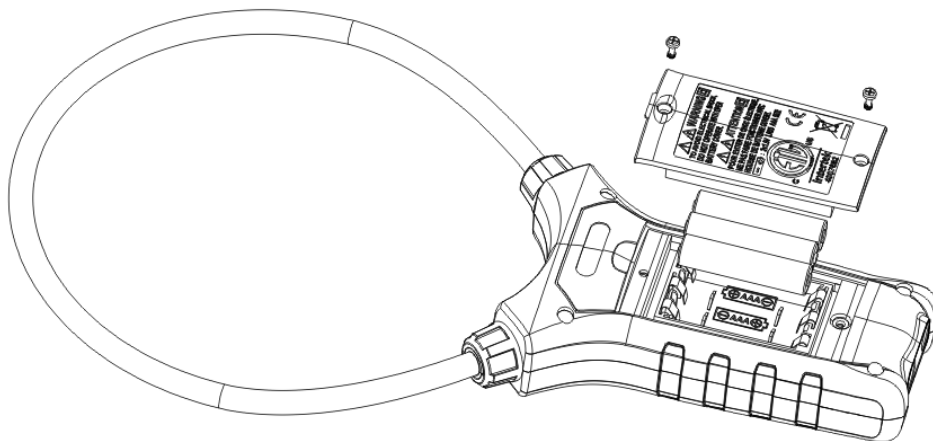

Figure 6