

D. OPERATION

Put your Solar Robot in the sunshine. Twist and tilt the solar panel so that the panel faces the directly into the Sun. This allows the panel to collect as much sunlight as possible. The motor should start running, making the Solar Robot walk slowly forwards. When you are not using your Solar Robot, keep it out of the sunshine so that the motor doesn't operate. Don't use the Solar Robot outdoors when it is raining as water may damage the solar panel and motor.

You may also use the Solar Robot indoors or at an indoor school science fair. Ask an adult for a desk lamp with a 60-watt incandescent light bulb (not a fluorescent energy saving bulb). The bulb will act as a simulated Sun. Shine the lamp close directly onto the solar panel from close up. The light should be enough to drive the Solar Robot. Warning: An adult's permission and supervision is required when using a desk lamp.

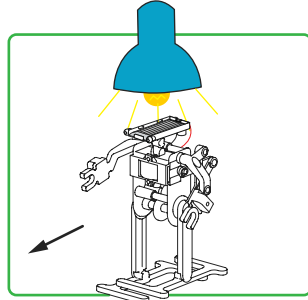

UNLIMITED GREEN & CLEAN FUN

Create different styles Solar Robots by recycling unused materials at home. They are GREEN robots powered by CLEAN energy.

Dinosaur Solar Robot

Recycle the package box to create this unique Dinosaur Robot. Push the two supports clips into the holes in the front of the gear case. Gently push out the dinosaur head parts and a tail shapes from the side of the box. Clip the back of the head into the support at the front of the gear case. Clip the top of the tail into the clip at the back of the gear case. Your Solar Powered Dinosaur is ready. You could re-use the rest of the package box to create other unique robot of your own design. Use your imagination!

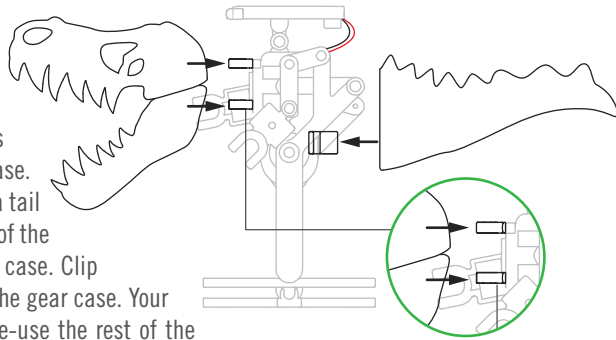

Monster Solar Robot

Recycle two plastic forks and a paper cup for this project. Push the handle of a plastic fork into the clamp on one arm. Secure with a screw. Repeat with a fork in the other arm. Push the head support into the upper hole in the front of the gear case. Push the rim of the paper cup into the clip. Draw a monster face on the paper cup to create your unique Solar Powered Monster.

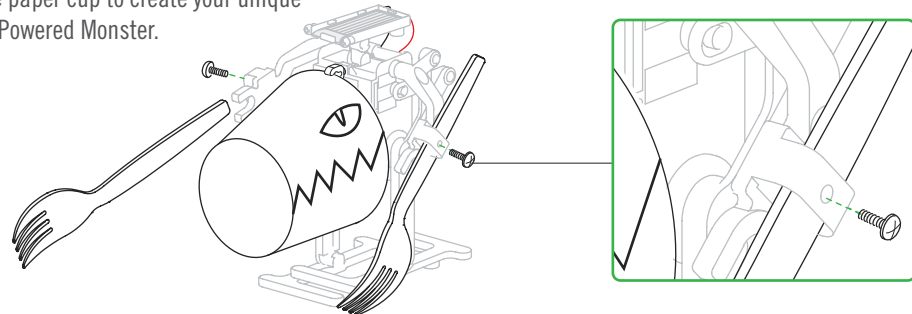

E. TROUBLESHOOTING

If your Solar Robot doesn't move:

- Ensure that the metal tabs of wires and the solar panel are tightly secured.
- Try giving the largest gear a gentle push to get it started.
- The sunlight may not be strong enough, or not hitting the solar panel straight on. Adjust the angle of the panel so that it faces directly at the Sun. If it's cloudy you may have to wait until a sunnier day.
- Check if all the gears and joints are lubricated.
- Check if any of the washered screws are installed too tight. Loosen them if necessary

If your Solar Robot walks backwards:

- Check whether the wires from the motor are on the wrong connectors. If so, swap them over.
- Check that the gears and joints are lubricated. Friction between the gear wheels will affect the performance of the motor.

If the feet of your Solar Robot hit each other:

- The cams are not at the right angle in relation to each other. Hold one of the legs in its highest position and rotate the other leg until it is in its lowest position.

F. HOW YOUR SOLAR ROBOT WORKS

The solar panel is made up of solar cells. When sunlight hits the solar cells, the cells create an electric current. The current goes along the wires to the motor and makes the motor spin. The motor spins fast. The gears in the gear box slow down the movement so that the large axle turns quite slowly. The large axle turns the two cam wheels, and the pins on the outsides of the cam wheels move the hips of the legs in circles. This movement makes the robot walk.

G. FUN FACTS

- Energy we get from the Sun is called solar energy. It's a renewable form of energy because the Sun keeps shining all the time.
- Most solar cells are made from a material called silicon. Most of the silicon used to make them comes from sand.
- We use solar cells to make electricity in all sorts of gadgets, from watches to garden lights.
- Solar vehicles work just like Solar Robot. They have arrays of solar panels that make electricity to work their electric motors.
- NASA's robot rovers called Spirit and Opportunity drive across the surface of Mars using electricity from solar cells.
- Solar Breeze is a solar-powered swimming-pool-cleaning robot. It swims across the water cleaning away dead leaves.
- Beambots are tiny solar-powered robots just few centimetres long. They collect energy from the Sun until they have enough to move a tiny way. Then they start collecting again.

Questions & Comments

We value you as a customer and your satisfaction with this product is important to us. If you have comments or questions, or you find any part of this kit missing or defective, please do not hesitate to contact our distributor in your country. You will find the address printed on the package. You are also welcome to contact our Marketing Support Team: Email: infodesk@4m-ind.com, Fax (852) 25911566, Tel: (852) 28936241, Web site: WWW.4M-IND.COM

GREEN SCIENCE SOLAR ROBOT

To Parents: Read all instructions before providing guidance to your children.

WARNING:
CHOKING HAZARD - Small parts.
Not for Children under 3 years.

Learn how to make a moving robot using solar panels and a motor. Put all the parts together and 'teach' your robot to do simple tasks. It can be your friend as well as your helper!

A. SAFETY WARNINGS

1. Adult supervision and assistance are required at all times.
2. This kit is intended for children aged over 8.
3. This kit and its finished product contain small parts which may cause choking if misused. Keep away from children under 3 years old.
4. Do not attempt to take the solar panel apart.

B. CONTENTS

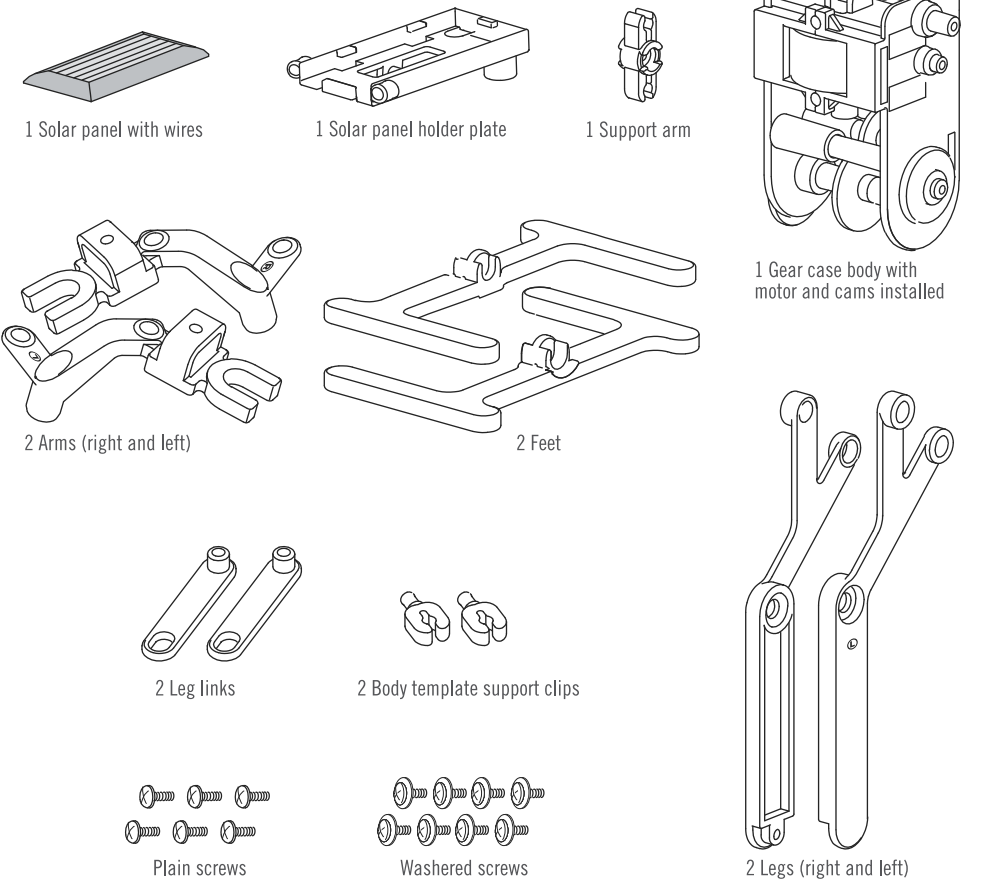

Also required but not included in this kit : small crosshead screw driver

C. ASSEMBLY

Take out the gear case body. Start by installing the left arm and leg of the robot. (Remarks: look carefully at the diagram to make sure you use the correct arm and leg, as the left and right are different. They are marked L and R).

1. Using a washered screw, attach a leg link to the top of the left leg. Make sure the link can swivel (if it is too tight, loosen the screw).

2. Using a plain screw, attach a foot to the left leg.

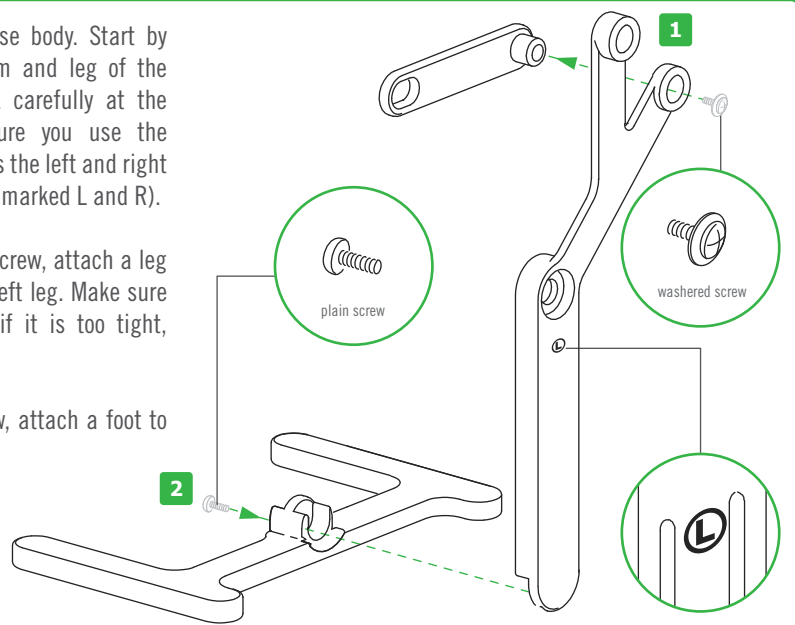

3. Push the 'hip' of the left leg onto the pin on the cam wheel on the left side of the gear case. Secure it with a washered screw. Don't over tighten the screw otherwise the wheel will not be able to turn.

4. Using a washered screw, attach the end of the leg link to the lower pin of the two pins on the gear case.

5. Find the small pin at the top of the left arm. Push the pin into the hole at the top of the leg.

6. Push the hole in the 'shoulder' of the arm onto the upper pin on the gear case. Using a washered screw, attach the shoulder to the gear case. Do not over tighten the screw.

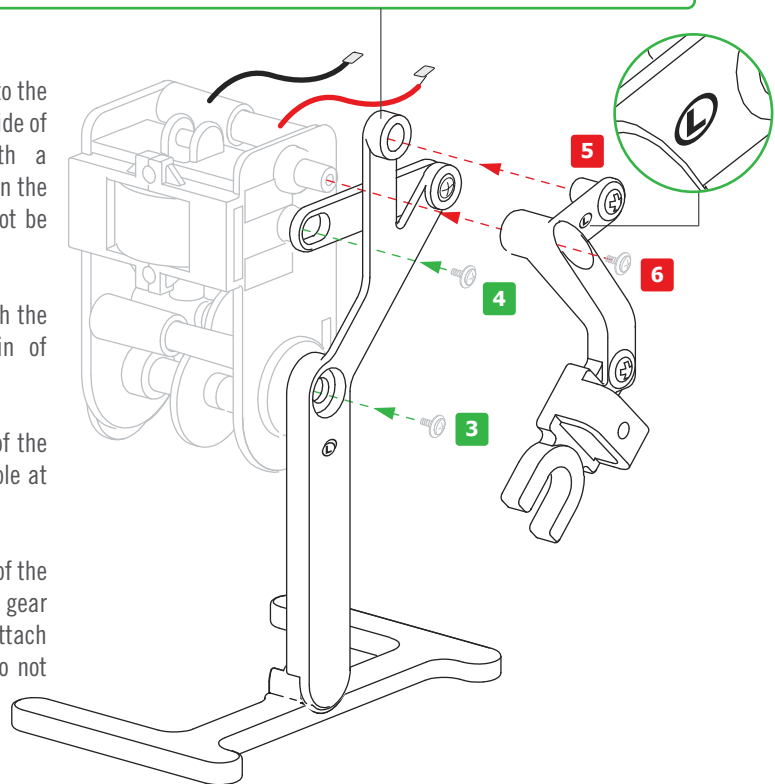

Repeat to install the right arm and leg.

7. Using a washered screw, attach a leg link to the top of the right leg. Make sure the link can swivel (if it is too tight, loosen the screw).

8. Using a plain screw, attach a foot to the right leg.

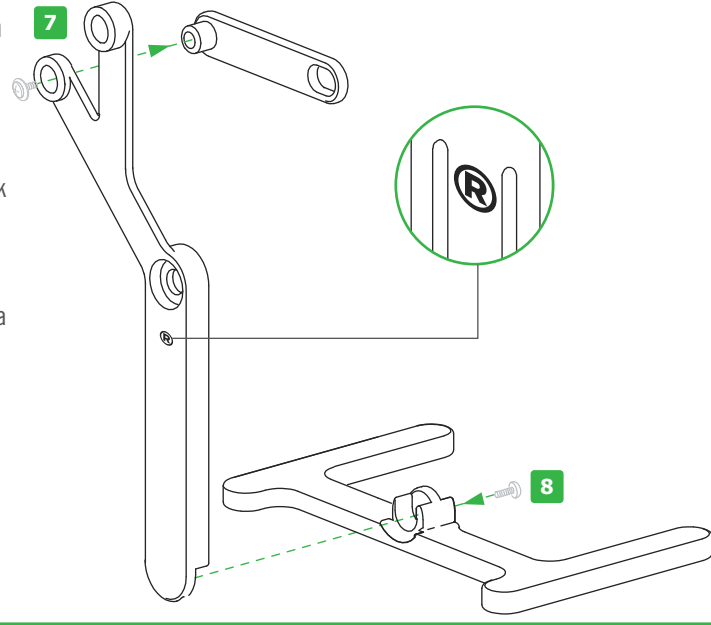

9. Push the 'hip' of the right leg onto the pin on the cam wheel on the left side of the gear case. Secure it with a washered screw. Don't over tighten the screw otherwise the wheel will not be able to turn.

10. Using a washered screw, attach the end of the leg link to the lower pin of the two pins on the gear case.

11. Find the small pin at the top of the right arm. Push the pin into the hole at the top of the leg.

12. Push the hole in the 'shoulder' of the arm onto the upper pin on the gear case. Using a washered screw, attach the shoulder to the gear case. Do not over tighten the screw.

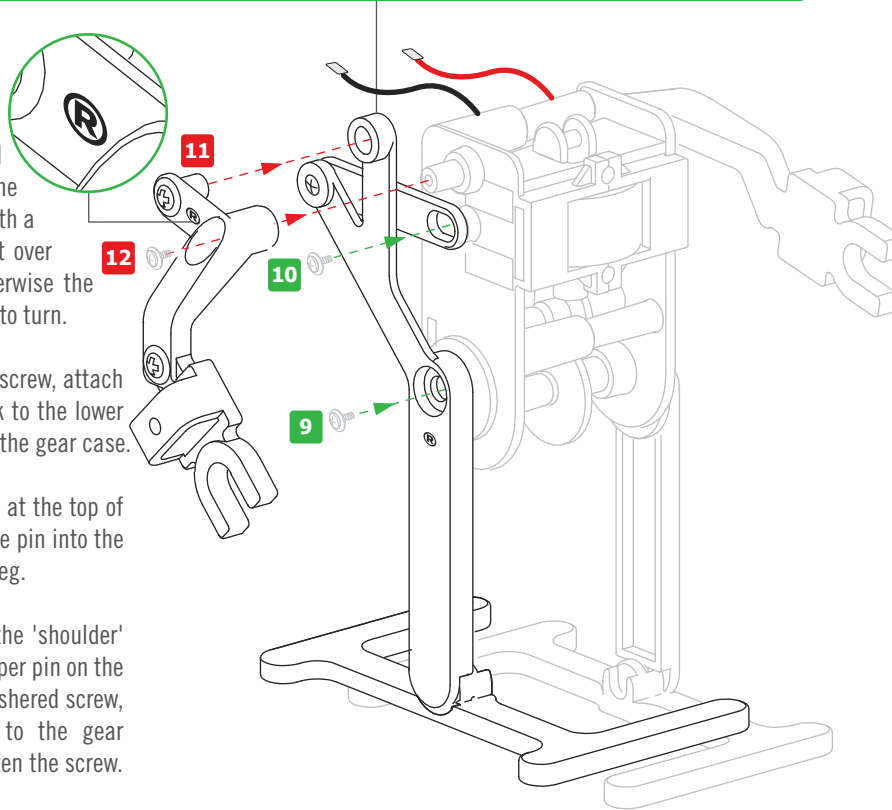

Installing the solar panel robot head

13. Secure two screws to the end of the the holder to make the robot's eyes.

14. Examine the solar panel. On the underside (the flat side) there is + sign and a - sign at one end. Slide the panel into the holder, with this marked end first, into the holder, until you hear a click.

15. On the underside of the solar panel holder are two holes for screws. These are for connecting the wires to the panel. Place the holder with the solar panel facing down, and with these holes facing up, and with the end of the holder with the holes facing away from you. The motor has two wires attached to it — one red and one black — each with a metal tab on the end. Slide the tab of the black wire into the right-hand connector (as you look at it) and secure it with a screw. Slide the tab on the red wire into the left-hand connector and secure this with another screw.

16. Clip the holder to the top of the support arm.

17. Clip the support arm to the connector on the gear box.

Lubricate the gears and the joints of the arms with small drops of oil (you can use cooking oil for this).

Congratulations! Your Solar Robot is ready to go.

