

## Operating Instructions for LED Strips

LED strips advantages are high brightness and balancing illumination, low power consumption, long lifespan, environmental friendliness, ease of installation, and a wide color palette.

To ensure the proper operation of the strip and to avoid malfunctions, you must adhere to the operating conditions, as well as properly carry out the power supply calculation and installation.

### Terms of Use:

Operating temperature:  $-40\text{ }^{\circ}\text{C}$  to  $+60\text{ }^{\circ}\text{C}$  (from  $-20\text{ }^{\circ}\text{C}$  to  $+50\text{ }^{\circ}\text{C}$  for the silicone-coated strip). Operating voltage:  $12\text{ V} \pm 5\%$  (exceeding the operating voltage range can result in malfunctions or can cause the strip to stop working completely).

LED strips without moisture proof coating (**IP20** rating) are designed for indoor use when relative humidity does not exceed 70%.

LED strips with silicone coating (**IP65** rating) are designed for indoor use in rooms with high humidity (up to 85%) and outdoor use under sheds that can safely protect a strip from direct sunlight or contact with droplets of liquid.

LED strips of **IP67** rating (PVC tube) can be used outdoors and under water up to 2 m deep.

### Calculating power of the power supply for a LED strip:

When choosing a power source, keep in mind the rule that its power should be higher than the total power of the strip connected and should have the margin of 25%.

In order to calculate the power of power supply you need to multiply the consumed power of one meter of the strip by the number of meters you connect to the power supply, and multiply the received figure by safety margin of 1.25.

For proper operation, LED strips should be powered not more than 5 meters away from a power source. Sections longer than 5 m should be connected to the main power line separately. It will increase the lifespan and will make illumination more balancing.

Wiring diagram of a monochrome strip:

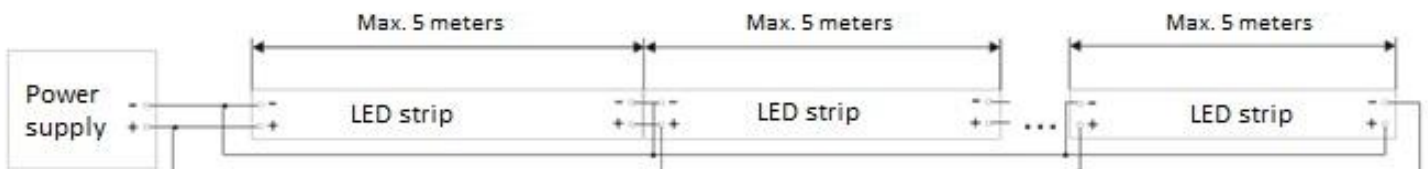

Wiring diagram of a RGB strip:

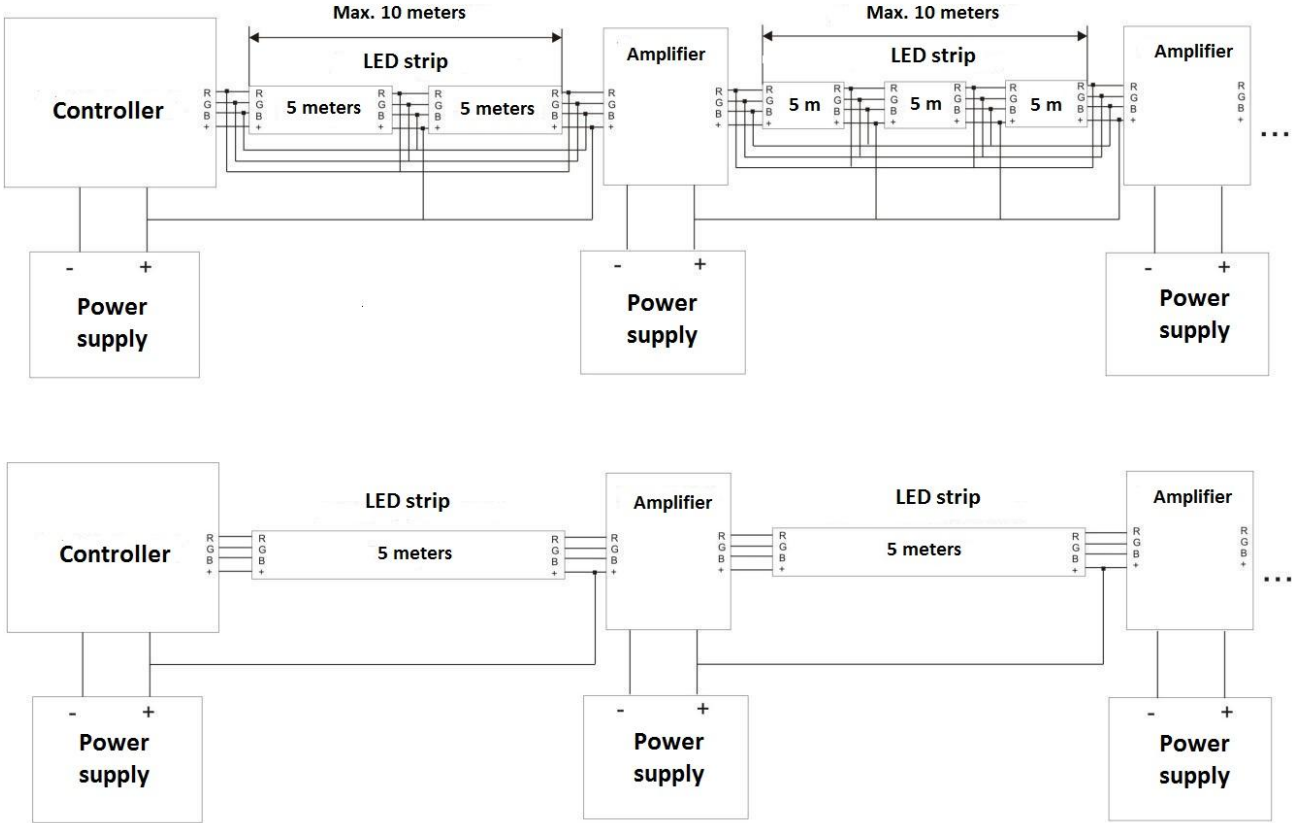

**Note: Minimum radii are only permitted in sections with no components.**

**If you need to connect more power, it is necessary to increase the wire sections proportionally to the supply current.**

Before switching on, make sure that the input power supply voltage corresponds to its operating range.

When working with the strip, observe the rules of protection against static electricity. Static electricity may damage LEDs, which will lead to reducing their lifespan and to subsequent failure.

Table 1. Recommended cross-sections of the copper power wires at a voltage of 12 V.

| Wire length 5 meters |            |                               |                   |
|----------------------|------------|-------------------------------|-------------------|
| Power, Watt          | Current, A | Wire section, mm <sup>2</sup> | Wire diameter, mm |
| 12                   | 1          | 0,13                          | 0.4               |
| 24                   | 2          | 0.25                          | 0.56              |
| 48                   | 4          | 0.5                           | 0.8               |
| 72                   | 6          | 0.75                          | 0.98              |
| 108                  | 9          | 1.12                          | 1.2               |

## Installing LED strips:

1. Clean, degrease and dry the surface where the LED strip will be mounted.
2. Remove the protective paper and apply the strip. Gently press the strip to the mounting surface until tightly glued (do not press LEDs, resistors, and controls). The surface where the strip is glued must be solid and without breaks to avoid damages to the strip.
3. Connect the LED strip with wire supply every 5 meters (wiring diagrams of LED strips are shown above).
4. The tape can be cut into 3 pieces with a minimum number of LEDs. Each cutting line is marked by a black stripe and has two pairs of pads on both sides for further connection.
5. Soldering strip segments can be performed only at designated areas (they are marked as “+/-” or “+ / RGB”). Soldering time should not exceed 10 seconds at a temperature less than 260 °C.

**Note: Troubleshooting of problematic situations you may encounter when installing and operating LED strips are described in Table 2.**

Table 2. Fault List and Troubleshooting Methods

| Major Faults and Troubleshooting Methods |                                                                           |                                                                                                                     |
|------------------------------------------|---------------------------------------------------------------------------|---------------------------------------------------------------------------------------------------------------------|
| Fault                                    | Cause                                                                     | Solution                                                                                                            |
| The LED strip does not work              | 1. Power supply does not work.                                            | Replace power supply.                                                                                               |
|                                          | 2. Short circuiting or automatic protection against power supply failure. | Cut out voltage from power supply and cut out the strip from power supply.<br><br>Find and clear the short circuit. |
|                                          | 3. Power supply fuse has blown.                                           | Replace the blown fuse with a new one and replace the power supply.                                                 |
|                                          | 4. When connecting the stripe, the polarity was not respected.            | Connect the LED strip to the power supply according to polarity.                                                    |
|                                          | 5. Power cable breakdown.                                                 | Restore the damaged contact.                                                                                        |
| A part of the LED strip does not work    | 1. Parts of the LED strip are not connected to each other.                | Check and restore the soldering at the joints of segments of the LED strip.                                         |
|                                          | 2. Short circuiting or automatic protection against power supply failure. | Replace LEDs and a strip segment with LEDs.                                                                         |

|                                       |                                                                           |                                                                                                                                                                   |
|---------------------------------------|---------------------------------------------------------------------------|-------------------------------------------------------------------------------------------------------------------------------------------------------------------|
|                                       | 3. LED strip circuit is damaged.                                          | Replace the damaged segment of the circuit.                                                                                                                       |
| The LED strip has low light intensity | 1. Power supply congestion.                                               | Replace the power supply with a more powerful one or increase the number of power supply sources.                                                                 |
|                                       | 2. Conductor loss is too high.                                            | Replace or add power wires; change the connection of the power supply source that ensures that every joint has the voltage not less than 95% of the declared one. |
|                                       | 3. Too many LED strips are connected.                                     | Connect every 5-meter line directly to the power wire.                                                                                                            |
| LEDs blink                            | 1. The contact of power wire is poor.                                     | Check and restore the soldering in the joints of power wire with the LED strip.                                                                                   |
|                                       | 2. Conductivity trouble of the LED strip resulting from mechanical abuse. | Replace the damaged segment of the circuit.                                                                                                                       |
| Certain LEDs do not work              | 1. Electrostatic breakdown                                                | Replace non-operating LEDs.                                                                                                                                       |