

Release date : 2011.01.12

Compatible with / 2009~ SKODA/VW model

RCD510 DELPHI

Specification & Installation

Contents

1. Before the installation

1.1 Main specification	3
1.2 Features	4
1.3 System diagram	5
1.4 Components	6
1.5 Exterior	7

2. Setup

2.1 DIP switch	8
2.2 KEYPAD	9
2.3 Factory mode	10
2.4 Rear parking guide line	11
2.5 OSD (on screen display)	13

3. Installation

3.1 Installation diagram	16
3.2 Cautions on installation	17
3.3 Installation	18

4. Troubleshooting

1.1 Main specification

1. Input Spec. (VIDEO INTERFACE)
 - 1 x **Analog RGBCs** (*for Navigation System*)
 - 1 x **REAR-C Input** (*Rear camera source*)
 - 3 x **AV Input** (*for TV, DVD ... NTST & PAL auto detection*)

2. Output Spec.
 - 2 x **CVBS OUTPUT** (*Video Out for installed headrest monitors*)
 - 1 x **Audio OUTPUT**
 - 1 x **LCD Output** (*LVDS video output*)
 - 4 x **Audio Select Output** (*12V power comes out from 4wires of cable by AV1, AV2, AV3 & Navi modes*)

3. Power Spec.
 - Input power : 8VDC ~ 16VDC
 - Power consumption : 12WATT in maximum level

4. Switching mode
 - Skip function of input video : Able to skip each input source via adjusting DIP switch.
 - Able to change a mode to another by using the mode switch.
 - Able to change modes and get back to the OEM screen through the genuine buttons.

1.2 Features

- Clear high definition screen
- NTSC, PAL system support
- Mode exchange via the original buttons
- Control over the position of NAVI, AV screen
- Additional function of adjusting the screen size of NAVI

1.3 System diagram

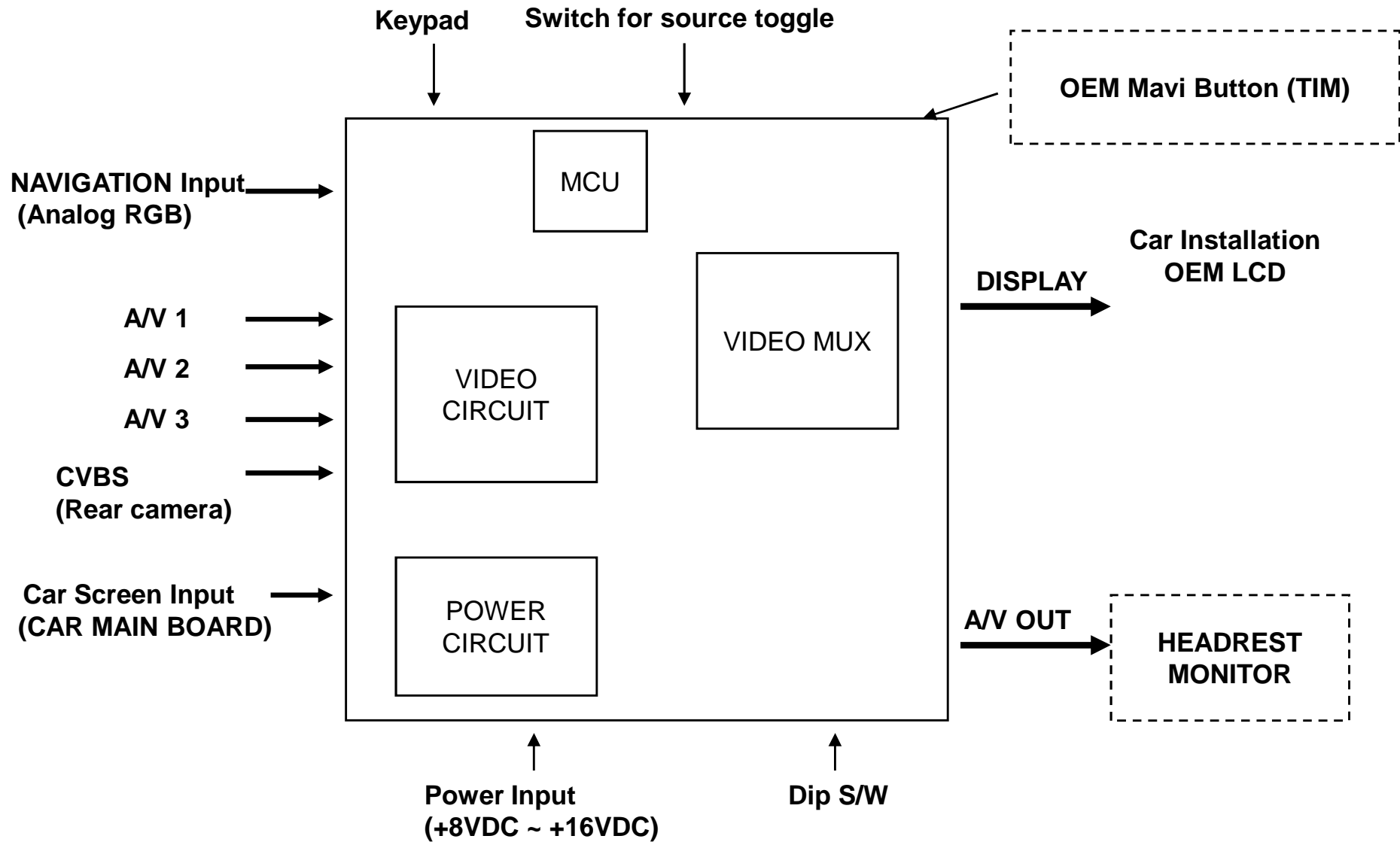

1.4 Components

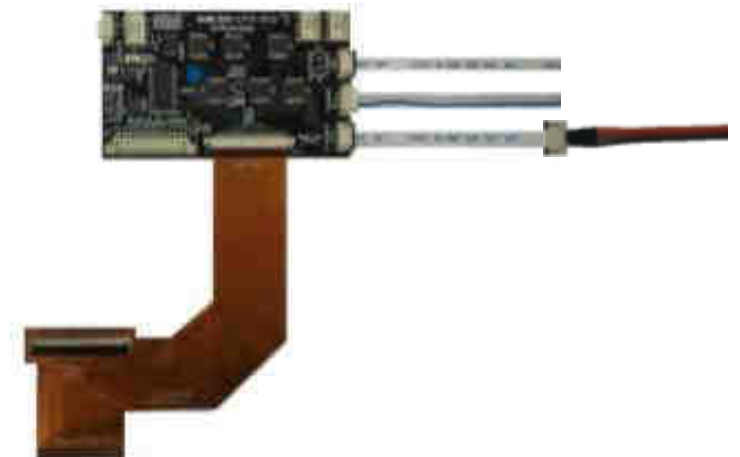

OSD Keypad : 1pc.
LCD cable : 1pc.
Navigation cable : 1pc.
Mode switch : 1pc.
Button cable : 1pc.
FFC cable : 2pc.

Power cable : 1pc.
A/V cable : 1pc.
IR cable : 1pc.
Sub Board : 1pc.
FPC cable : 1pc.
Extension cable : 1pc.

1.5 Exterior

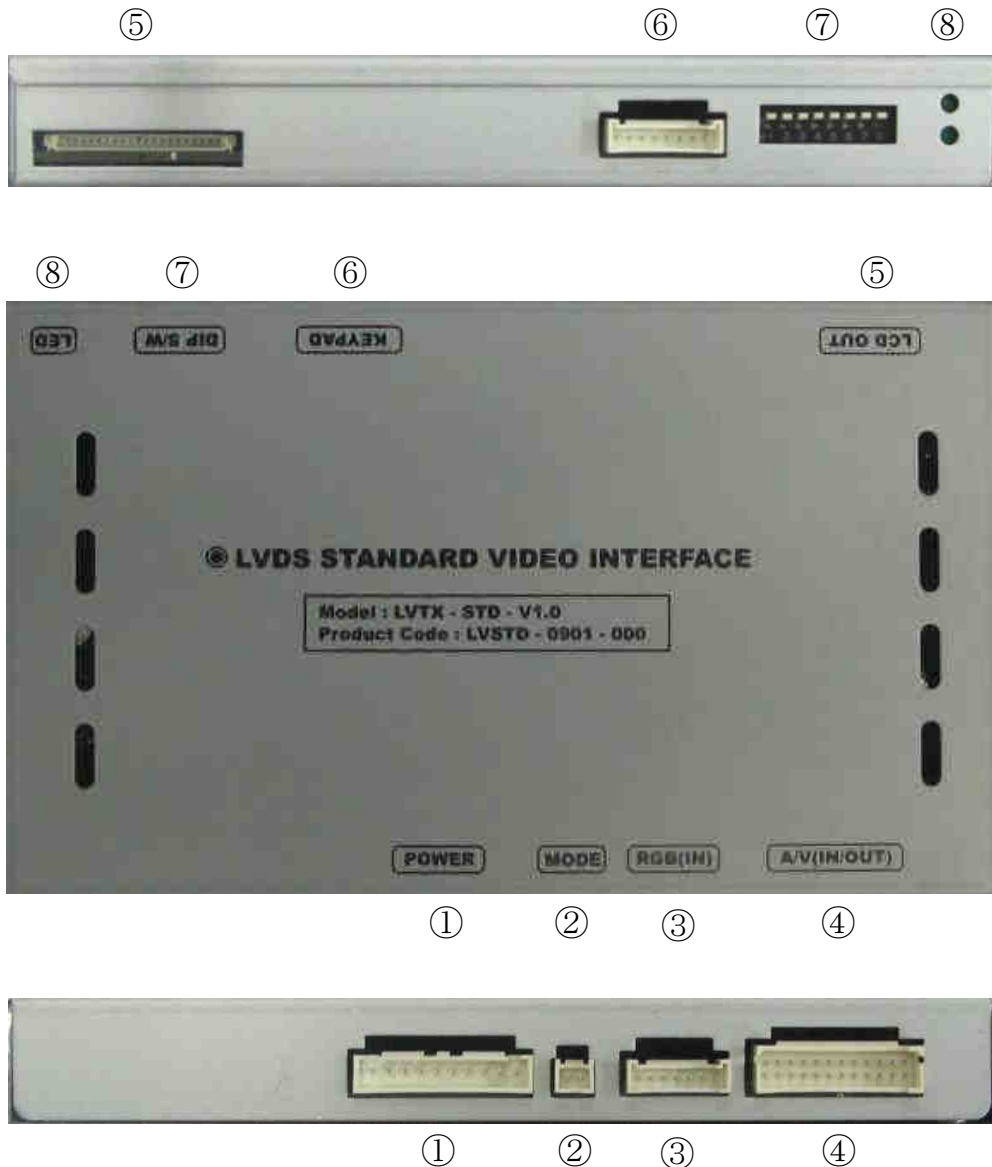

Product dimension

155mm (Horizontal length)
93mm (Vertical length)
20mm (Height)

- ① POWER
- ② MODE
- ③ RGB (IN)
- ④ AV(IN/OUT)
- ⑤ LCD OUT
- ⑥ KEYPAD
- ⑦ DIP S/W
- ⑧ LED

2.1 DIP switch

DIP #	Function	DIP S/W selection
1	RGB Input	ON : RGB input is OFF OFF : RGB input is ON
2	A/V1 Input	ON : A/V1 input is OFF OFF : A/V1 input is ON
3	A/V2 Input	ON : A/V2 input is OFF OFF : A/V2 input is ON
4	A/V3 Input	ON : A/V3 input is OFF OFF : A/V3 input is ON
5	NOT USED	
6	NOT USED	
7	Rear Mode	ON : External Rear Camera OFF : OEM Rear Camera
8	OEM Picture	ON : OEM-OEM-RGB-AV1, AV2, AV3 OFF : OEM-RGB-AV1, AV2, AV3

※ **ON : DOWN, OFF : UP**

※ DIP S/W usage example

- Input mode use : A/V2, A/V3
- Use original navigation

- ▷ DIP S/W : 1,2 → ON (INPUT MODE SKIP)
- ▷ DIP S/W : 3 → OFF (enable A/V2)
- ▷ DIP S/W : 4 → OFF (enable A/V3)
- ▷ DIP S/W : 5, 6, 7 → OFF
- ▷ DIP S/W : 8 → ON



2.2 KEYPAD

※ **FACTORY MODE (Interface setting)**

1. Press “UP” button about 2 seconds long and you will approach FACTORY mode.
2. Also you can get there in pressing these keys in this sequence; “UP” → “DOWN” → “UP” → “MENU”



Key	Function
MENU/EXIT	OSD Menu
SEL/INPUT	Selection
UP	Move UP or LEFT (<i>press about 2 sec. – Factory Mode</i>)
DOWN	Move DOWN or RIGHT (<i>press about 2 sec. – Factory Reset all Settings</i>)

2.3 Factory mode

※ **FACTORY mode** – Press “UP” button on the keypad long about 2 seconds or press these buttons in this sequence; “UP”→”DOWN”→”UP”→”MENU”

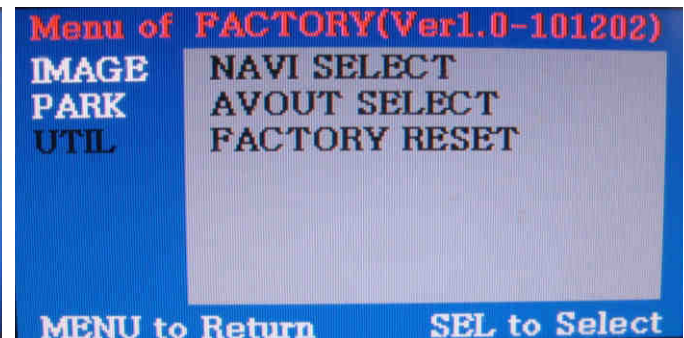
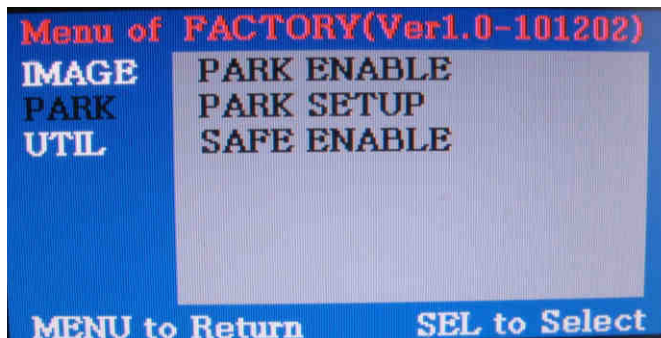
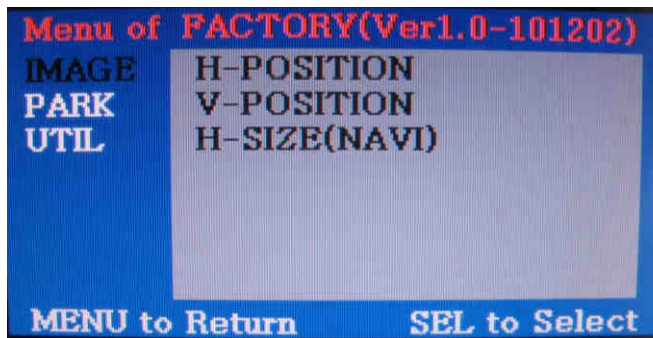

IMAGE

- H-POSITION : control over the horizontal position of the screen
- V-POSITION : control over the vertical position of the screen
- H-SIZE : control over the size of NAVI screen

PARK

- PARK ENABLE : able to choose whether the rear guide line is displayed or not with rear gear. (default-ON)
- PARK SETUP : able to adjust the position of the rear guide line with the keypad.
- SAFE ENABLE : The function that forbids drivers to change the LCD to DVD or A/V while driving. User returns to the main screen by this function. (Default : off)
(Refer to the page#11)

UTIL

- NAVI SELECT (**NOT USED**)
- AVOUT SELECT : making a choice of AVOUT output in the OEM & NAVI screen (Default – AV3)
- FACTORY RESET : reset

2.4 Rear parking guide line

※ **FACTORY mode** – Press “UP” button on the keypad long about 2 seconds.

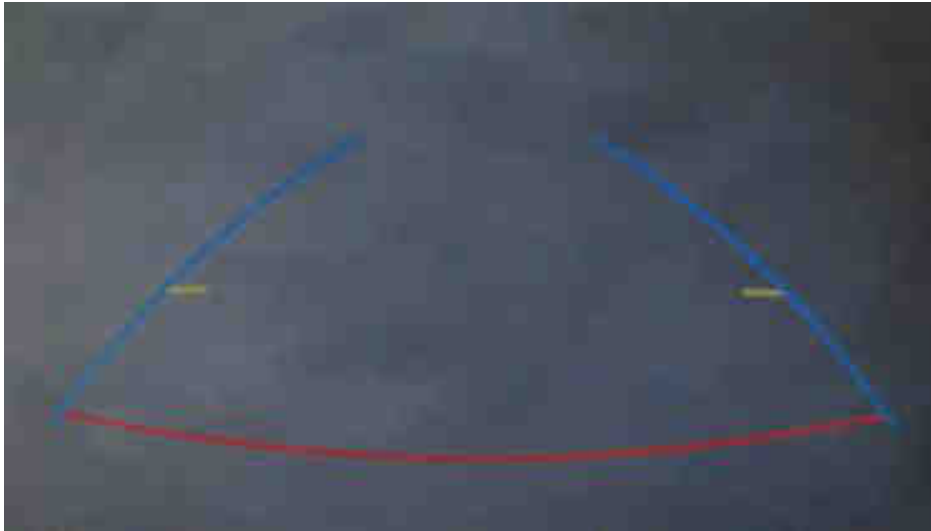

① Once you change up into rear gear, the rear parking guide line will automatically appear on the screen like the left picture.

※ **FACTORY default : DISPLAY - ENABLE**

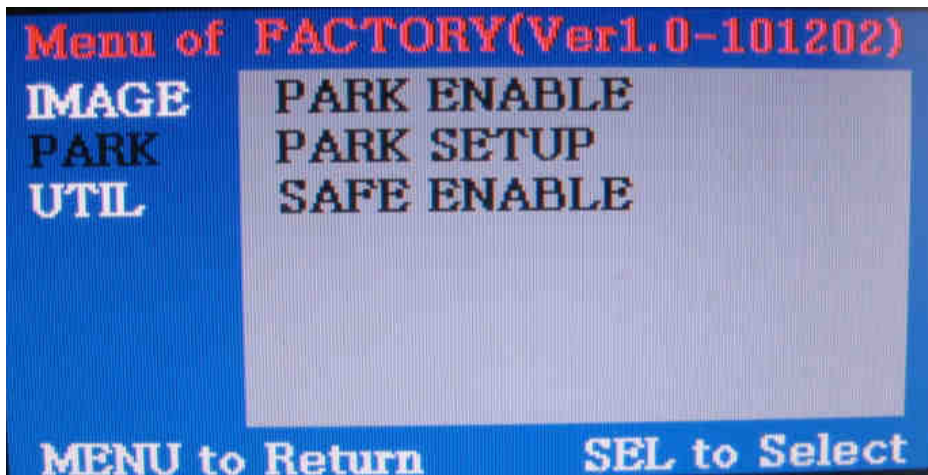

② If you press “UP” button on the keypad about 2 seconds long, you can see the left image on the screen. Now that you choose “PARK SETUP” and press “OK” on the keypad, you can control the width of the rear parking guide line.

2.4 Rear parking guide line

※ FACTORY default -Types:0, H_Pos:50, V_Pos:120

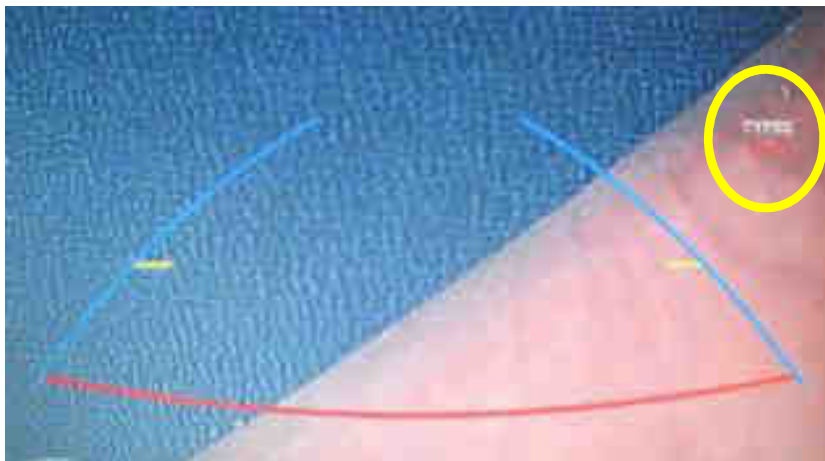

level 0



level 4

③ The width of the rear parking guide line has 5 level(0~4). After you control the level with “UP”, “DOWN” button on the keypad, you can move to the horizontal positioning mode after pressing “SEL” button and saving process. (The current state is displayed right-top.)



④ After you control the horizontal position with “UP”, “DOWN” button on the keypad, you can move to the vertical positioning mode after pressing “SEL” button and saving process. Once you finish that and press “SEL”, all the things will be saved. (Adjustable between level 0 and level 255.)

※ Unless you want the rear parking guide line, set the value of “PARK ENABLE” as “OFF”.

2.5 OSD (on screen display)

※ OSD : Press “MENU” button on the keypad.

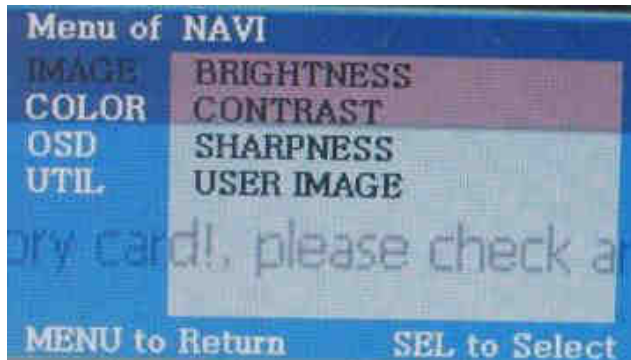

Analog RGB Mode

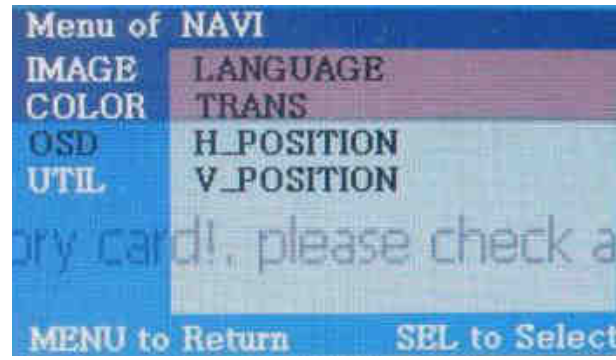

Analog RGB Mode



Analog RGB Mode

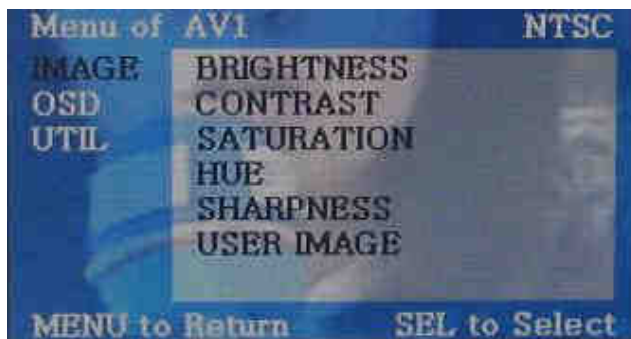

Video Mode



Video Mode



Video Mode

IMAGE

- BRIGHTNESS : adjusting brightness
- CONTRAST : adjusting contrast
- SATURATION : adjusting saturation
- HUE : adjusting hue
- SHARPNESS : adjusting sharpness
- USER IMAGE : able to make a choice among 4 set-colors of the screen

OSD

- LANGUAGE : choice of language
- TRANSPARENT : control over the transparency of OSD
- H_POSITION : control over the horizontal position of OSD
- V_POSITION : control over the vertical position of OSD

UTIL

- FACTORY RESET : able to reset the whole value of the NAVI or AV screens to the default.

3.1 Installation diagram

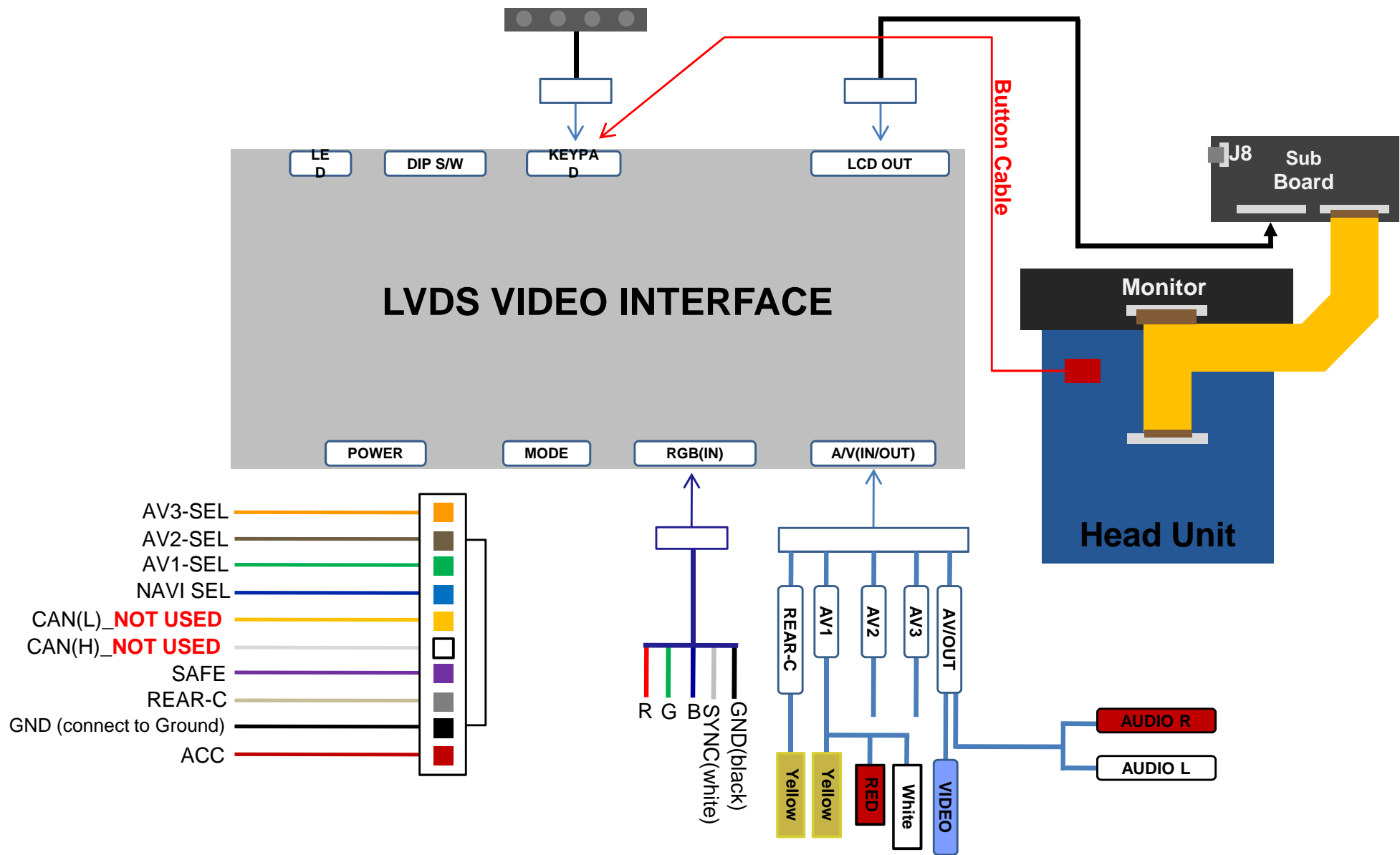

3.2 Cautions on installation

- Ignition key should be taken off before starting installation, interface power connection must be the last step in installation.
- Power cable should be separated when connecting interface.
- Should be no any electronic devices or magnetic pole around installation place.
- All steps of installation should be done by well-trained specialist.
- Dismantling without manufacturer's permission can not be guaranteed, (No permission to break attached label on the board.)
- Kindly check all parts are in the box, when receiving the product, if anything missing, inform to the supplier or manufacturer.
- According to our sales policy, any problems caused by user's mistake, careless can not be guaranteed.

3.3 Installation

3.3.1 Dividing the monitor



First of all, divide the case of the head unit. And divide the monitor from the head unit.

3.3.2 Connecting the FPC cable enclosed in the package

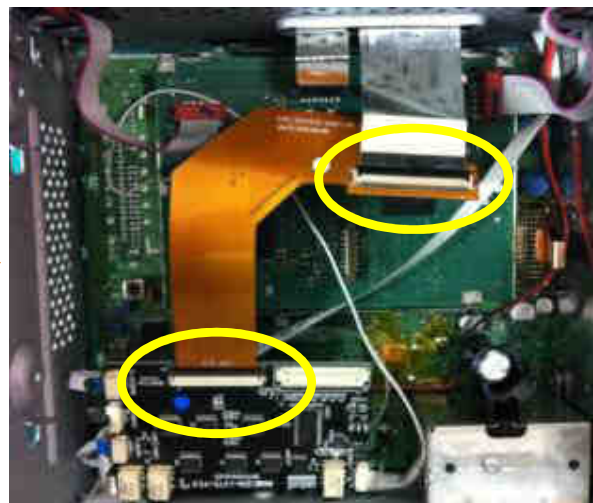
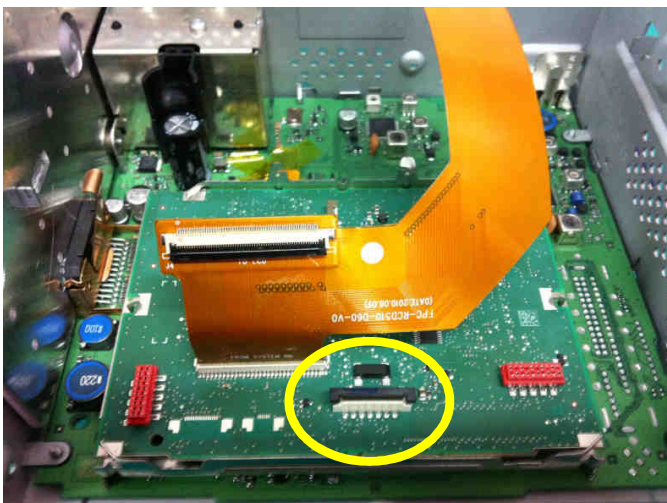

Connect the FPC cable enclosed in the package like the left picture.

- From System BD : connecting to the head unit
- To LCD : connecting the original FPC (connected to the monitor)
- SUB B/D : connecting with the sub board (enclosed in the package)

3.3 Installation

3.3.3 Connecting the original button

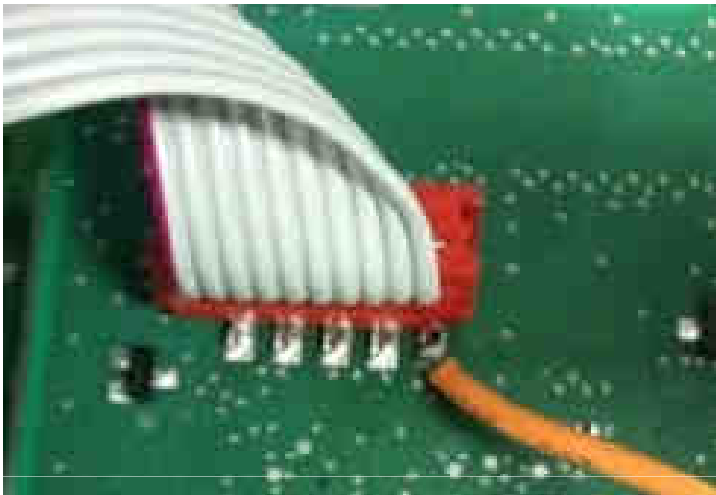

① Solder the original cable (enclosed in the package) to the extreme right point of the original button cable connector.



② Pin#5 of GROUND cable



③ Connect the opposite end of the soldered orange cable with pin#5 of GROUND cable as above.

3.3 Installation

3.3.4 TOUCH

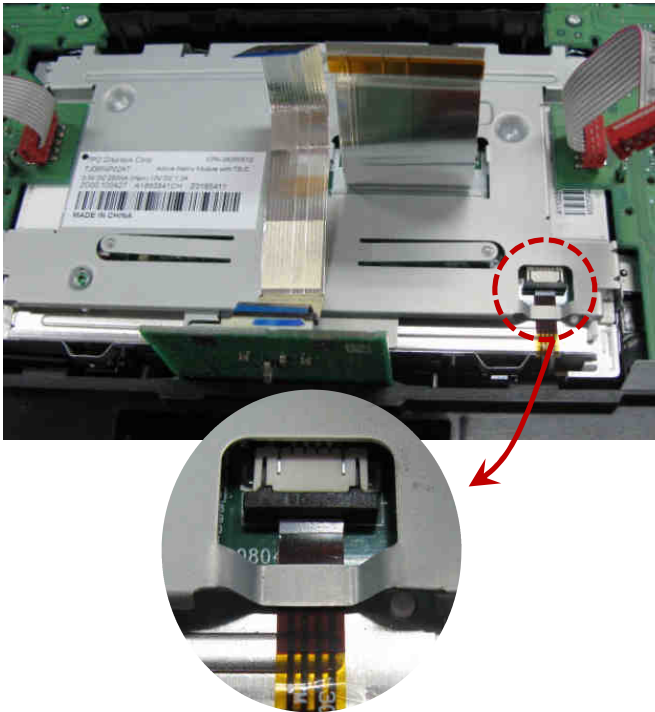

① If you divide the LCD cover, you can see the state connected with the original TOUCH cable like the left picture. After disconnecting this TOUCH cable, connect that like the bottom picture.



② Connect FFC cable(enclosed in the package) to the connector at the backside of the monitor. And then connect the extension cable(enclosed in the package) with the original TOUCH cable.

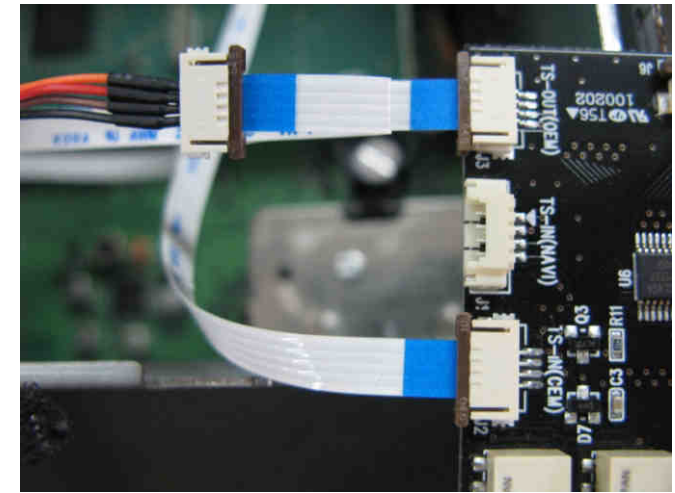

③ Connect the extension cable(connected to the original cable) to the SUB board using FFC cable(enclosed in the package) (TS-OUT). Connect FFC cable(connected to the connector at the backside of the monitor) to "TS-IN" spot in SUB board.

3.3 Installation

3.3.5 Finish

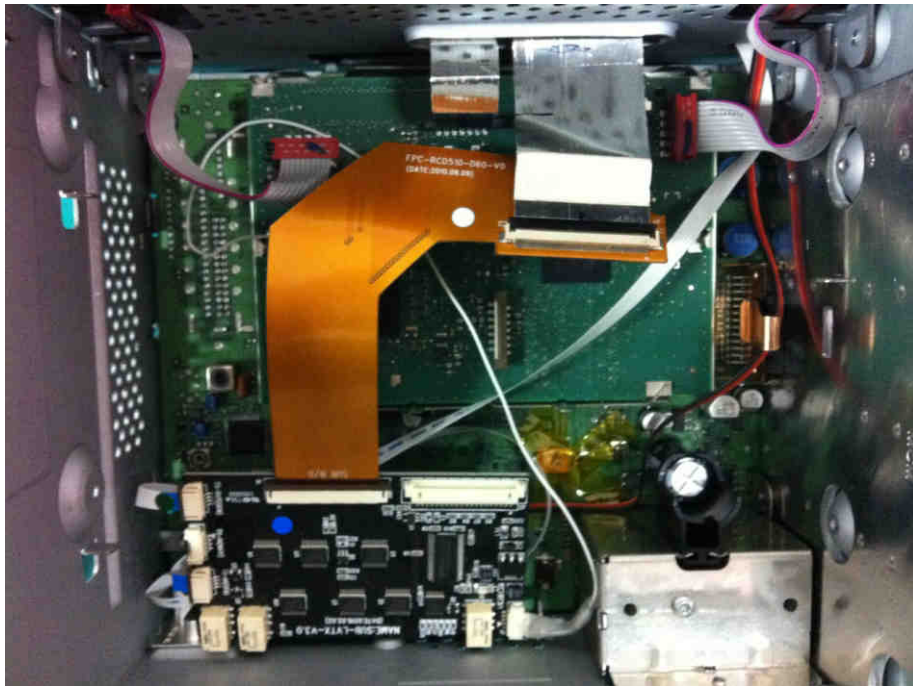

① Finish

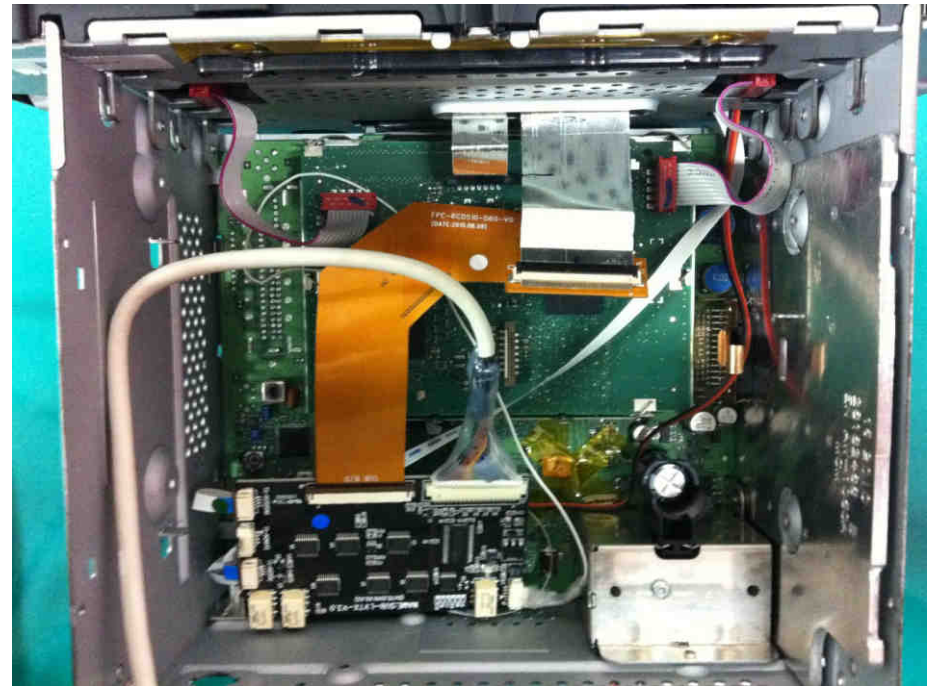

② Finish (with LVDS cable)

4. Troubleshooting

Q. I can not switch A/V sources.

A. Check IR or Ground cable connection. Check LED lamps in the interface, if it is not on, check power cable.

Q. All I got on the screen is black.

A. Check second LED lamp of the interface is on, if not, check A/V sources connected are working well.
(Second lamp indicates AV sources connected works well.) Check interface connection has been done well.

Q. Displayed image color is not proper. (too dim or not suitable color)

A. Try to select "INITIAL" in OSD menu, if it does not work, inform the manufacturer.)

Q. Rear camera image does NOT appear.

A. Set DIP switch #7 in "ON"

Q. Unwanted A/V mode is displayed. (A/V source switching order : OEM->RGB->AV1->AV2->AV3)

A. Check DIP Switch Setting.

Q. OEM image is not displayed.

A. Check interface's LCD In/Out cable connection. If the status keeps on, inform the manufacturer.

Q. Screen only displays white like left picture.

A. Check LCD out cable is connected well, if this status keeps, inform the manufacturer.