

CS9100 Installation in Mazda CX-7, CX-9 Using the NAV2NAV V2.1 Adaptor

⚠️ Disconnect the negative terminal of the accumulator before installing the CS9100 to avoid errors in the ECU. In order to install CS9100, remove the original navigation system.

Remove the original navigation system (**fig. 1**). You can find it at one of the following locations:

- Under the front passenger seat in CX7;
- In the trunk (on the right) in CX9 (**fig. 2**).



Figure 1



Figure 2

Before you connect the device, be sure to activate the appropriate protocol of the **NAV2NAV** adaptor using the **DIP switches** (**fig. 4**).



Figure 3



Figure 4

Set the **DIP switches** (**fig. 4**) on your **NAV2NAV** adaptor according to the following table.

| DIP Switch # | 1 | 2 | 3 | 4 | 5 | 6 | 7 | 8 |
|----------------|----|-----|-----|-----|----|-----|-----|-----|
| Switch Setting | ON | OFF | OFF | OFF | ON | OFF | OFF | OFF |

How to install the GPS antenna

Removal of the original navigation system allows you to connect **CS9100** to the car's original GPS antenna. The best way to do this is to desolder the plastic socket (**fig. 5**) from the original wiring and solder a 10cm coaxial cable fitted with a SMA Male connector (**fig. 6**) with the wiring. The **CS9100** navigation system is fully compatible with the original antenna in all specifications.

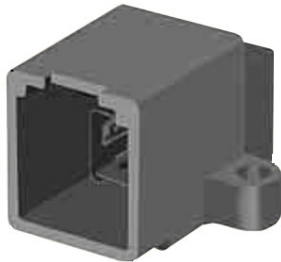

Figure 5



Figure 6

Rear spoiler is the best place for aftermarket GPS antenna installation (**fig. 7**) (cable length allows for it). If there is no rear spoiler in your car you can use a fin-shaped antenna (not included in the package) (**fig. 8**). You can also install antenna under the windshield, on or under the plastic panel (**fig. 7**)

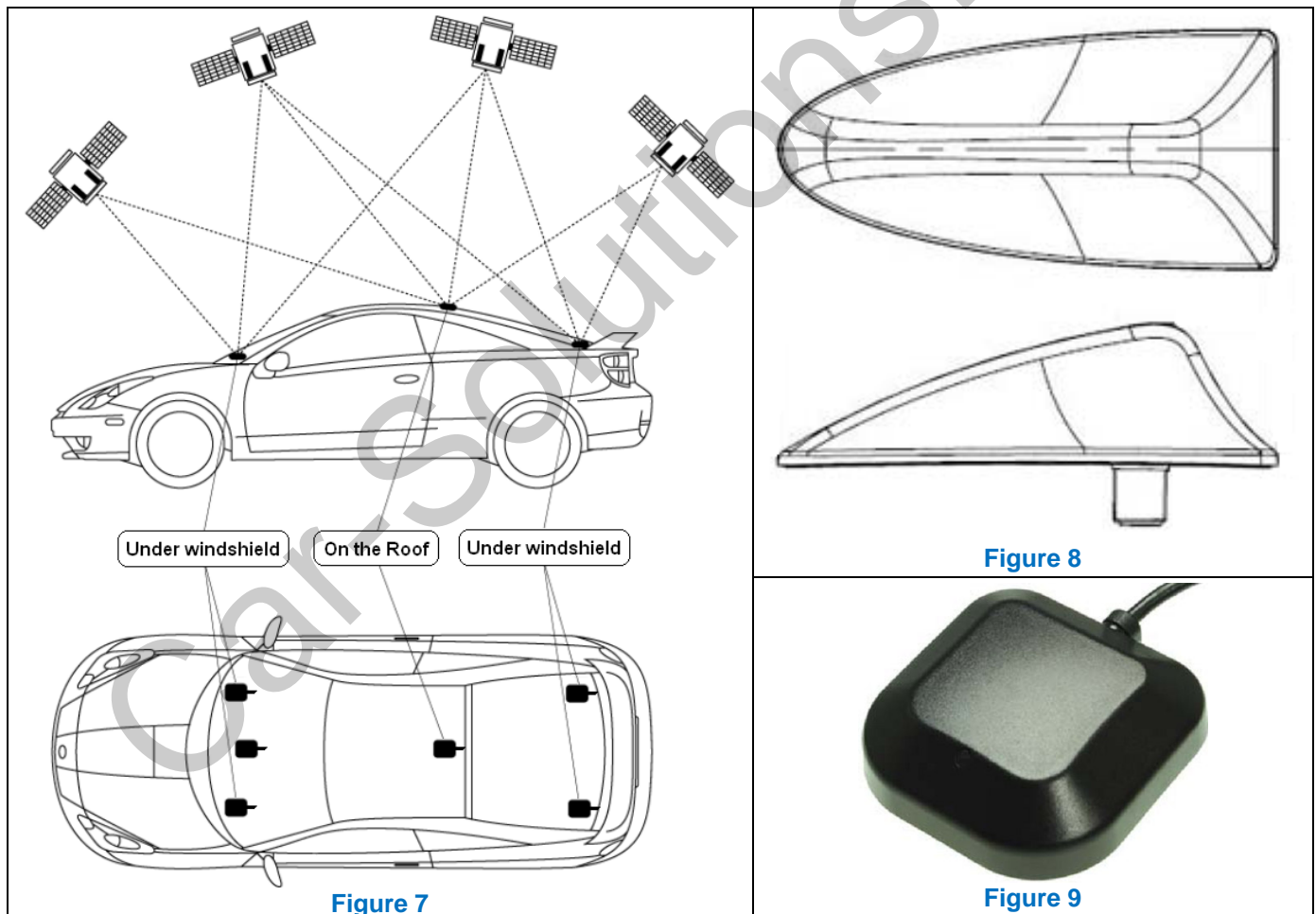

Figure 7

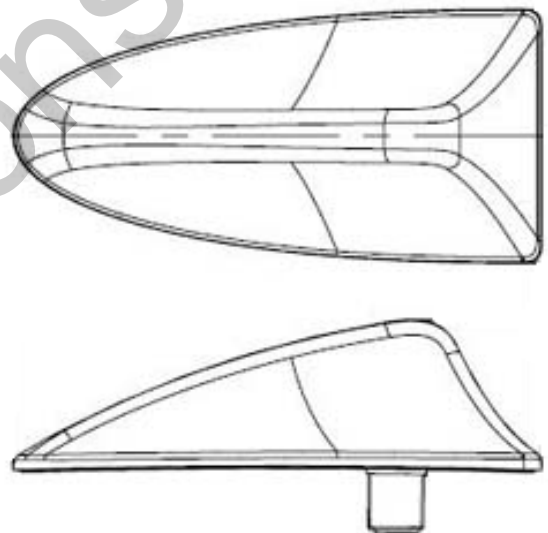

Figure 8



Figure 9

- ⚠ When installing GPS antenna in a concealed position, make sure there is no metal above it.
- ⚠ Install GPS antenna with the magnetic base down (**fig. 9**)
- ⚠ If your car windshield and windows are made of thermal glass, fix GPS antenna on the roof or rear spoiler.

When you switch on the **CS9100** navigator for the first time, handle all setup procedures using the remote control or a USB mouse. If **CS9100** doesn't respond to the remote control, you'll need to synchronize them. Press **Return** and **Home** simultaneously and hold for 1s. Synchronous flashing of LEDs indicates a successful synchronization.

For correct operation of the navigation system, activate an appropriate control protocol:

1. Use the remote control to enter **Settings** in the main menu.
2. Choose **System Config** (fig. 10).
3. Go to the **Panel I** tab.
4. Choose the **Kenwood** protocol (fig. 11).
5. Press **SAVE**.



Figure 10

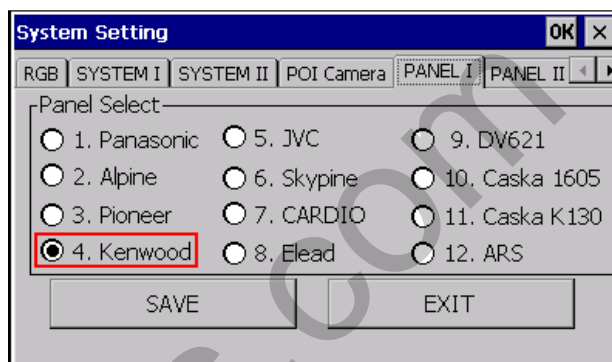

Figure 11

To be able to control the navigation system using the original touch panel without the remote control, you'll need to calibrate it:

1. Use the remote control to enter **Settings** in the main menu.
2. Choose **Calibration**.
3. Use a stylus from a PDA or any other non-sharp object to click on the marks that appear on the screen. (fig. 12)
4. Press **EXIT**.

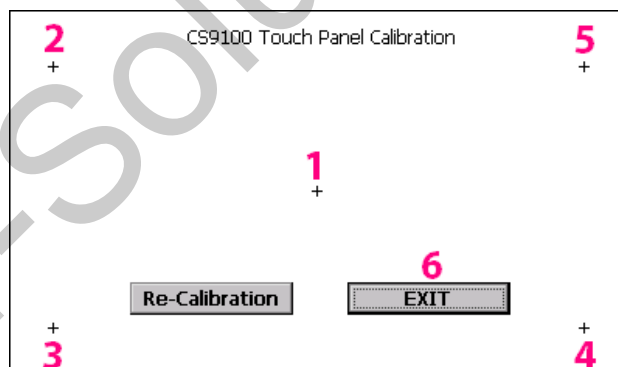

Figure 12

Once you finish all setup procedures you can activate **Autorun** of the navigational software (or any other software) in the **Settings** menu (fig. 10).



You don't have to cut off the wire connectors of the original navigation system. All operations can be completed by simply plugging the NAV2NAV adapter connectors into original sockets.



This type of connection works only for cars with an external navigation system.



The built-in clock will stop working after removal of the original navigation system. In some cases this problem can be solved by disconnecting the negative terminal at 12:45 and connecting it back at 13:00.